

ACADEMIC LEARNING PACKETS

PHYSICAL EDUCATION

Volume 1

Copyright © 1997, 2007 by The Advantage Press, Inc.

Limited license to photocopy at purchasing school only
All other rights reserved

For information, address The Advantage Press, Inc.
P. O. Box 3025, Lisle, Illinois USA 60532
Telephone: (630) 960-5305

TABLE OF CONTENTS

ACADEMIC LEARNING PACKETS PHYSICAL EDUCATION

INSTRUCTIONS AND SUGGESTIONS

Learning Packet #1: VOLLEYBALL

Student Response Packet

Learning Packet #2: BADMINTON

Student Response Packet

Learning Packet #3: TENNIS

Student Response Packet

Learning Packet #4: BASKETBALL

Student Response Packet

Learning Packet #5: BOWLING

Student Response Packet

Learning Packet #6: SOCCER

Student Response Packet

Learning Packet #7: ARCHERY

Student Response Packet

Learning Packet #8: WRESTLING

Student Response Packet

Learning Packet #9: GOLF

Student Response Packet

Learning Packet #10: FIELD HOCKEY

Student Response Packet

Learning Packet #11: BASEBALL

Student Response Packet

LICENSE TERMS
FOR
ADVANTAGE PRESS LEARNING PACKETS

The following License Terms govern your use of the Advantage Press, Inc. Learning Packets.

1. **License Grant.** The Advantage Press, Inc. grants you a license to use the Learning Packet Files contained on the enclosed CD. “Use” includes using, storing, loading, installing, executing, and displaying the Learning Packet Files. You may modify the Learning Packet Files.

2. **Ownership.** The Learning Packet Files are owned and copyrighted by The Advantage Press, Inc. Your license confers no title to, or ownership in, the Learning Packet Files and is not a sale of any rights in the Learning Packet Files.

3. **Copies and Adaptations.** You may only make copies or adaptations of the Learning Packet Files for archival purposes and for dissemination in the Purchasing School Building. You must reproduce all copyright notices in the original Learning Packet Files and on all copies or adaptations. You may not copy the Learning Packet Files onto any public network.

4. **General Use.** You may install and use a copy of the Learning Packet Files on your school’s computer(s) including network server and portable computing devices by adhering to the provisions in numbers five and six below.

5. **Server Use.** You may install and use a copy of the Learning Packet Files on your Internal computer Network for use on computers within the physical purchasing site. No other network use is permitted, including, but not limited to using the Learning Packet Files either directly or through commands, data or instructions from or to a Computer not part of your internal network, for internet or web hosting services or by any user not licensed to use this copy of the Learning Packet Files through a valid license from The Advantage Press.

6. **Computer Use.** The primary user of the Computer on which the Learning Packet Files are stored may also make a second copy for his or her exclusive use on a portable Computer provided the Learning Packet Files are not being disseminated onto a computer network outside of the purchasing site.

7. **Termination.** The Advantage Press, Inc. may terminate your license, upon notice, for failure to comply with any of the above terms. Upon termination, you must immediately destroy the Learning Packet Files, together with all copies, adaptations and merged portions in any form.

PHYSICAL EDUCATION PACKET SYSTEM

INSTRUCTIONS AND SUGGESTIONS

Physical Education Learning Packets provide constructive learning experiences for students who do not, or cannot, meet physical education requirements. This volume contains 11 Learning Packets, ranging from volleyball to baseball.

The purpose of these Learning Packets is to acquaint students with particular sports or other physical activities. There should be a sufficient variety among these packets to interest almost any student, whether or not he or she is particularly active in sports.

In some cases, you may want to distribute these packets to students who, for physical or health reasons, cannot participate in sports and other strenuous activities, but who would like to know how games are played and scores are kept so that they can feel more a part of these school activities, and be a more informed spectator. Physical Education Learning packets will give these students the rudiments of each sport or activity.

You may also have students who have no apparent interest in physical education, and habitually present a variety of excuses not to participate (such as “forgetting” to bring their gym shoes or clothes to class, etc.). These packets can be used as a means of discouraging such students from making excuses for not participating.

There may also be students who would like to know more about different sports and would welcome an opportunity to read about the history and techniques of a particular sport in addition to being a player. In this case, the packets may be used to provide extra credit for such inspired students.

Physical Education Packets also provide instant lesson plans for any substitute teacher. All that is necessary is access to a photocopier. As many copies of a packet as needed can be made. PE teachers can also use Physical Education Packets to introduce a sport or activity to a class. In addition, you may want to use the packets as a unit lesson, and utilize the questions and puzzles for a unit test.

Each packet consists of 4 or 5 pages of narrative material for each sport or physical activity, including an introduction, history, description of how the game is played, and individual techniques for playing.

After the student has read the narrative, there are 10 questions, a crossword puzzle, and a wordsearch to evaluate student mastery of the materials.

INSTRUCTIONS FOR USING THE PACKETS

1. Make extra copies of your Learning Packets. Don't give students the master copies. Save them for making additional copies.
2. Give each student one of the packets for him or her to read. Also give him or her the corresponding questions, crossword puzzle and wordsearch puzzle. Each packet is designed to be a 45-minute lesson.
3. A teacher answer section is provided with each packet for ease of grading. Graded Physical Education Packets can give you an objective assessment tool for arriving at quarter or semester grades.

VOLLEYBALL

PACKET # 1

INSTRUCTIONS

This Learning Packet has two parts: (1) text to read and (2) questions to answer.

The text describes a particular sport or physical activity, and relates its history, rules, playing techniques, scoring, notes and news.

The Response Forms (questions and puzzles) check your understanding and appreciation of the sport or physical activity.

INTRODUCTION

Volleyball is a popular sport which can be played both indoors and outdoors. It appeals to people of all ages and skill levels. It is fast-paced, with constant jumping and running, and thus provides a strenuous aerobic workout. It also requires mental alertness and quick, precise physical reactions.

Many associate volleyball with the beaches of southern California and in fact, a number of professional players get their start by playing beach volleyball. However, volleyball is popular not only on the beaches, but in virtually every country of the world. In 1964, it was officially recognized as part of the Olympic Games.

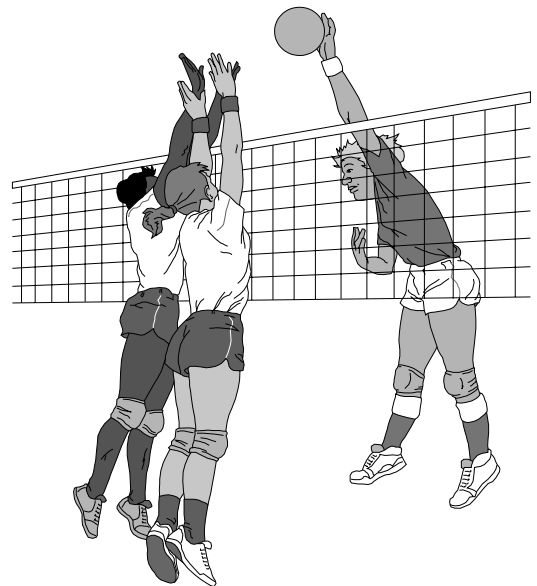

HISTORY OF THE GAME

Volleyball originated in Massachusetts in 1895 when the director of a local YMCA used the bladder of a basketball for a ball and a tennis net as the first volleyball net. The game was regulated by the YMCA until 1928 when the United States Volleyball Association was founded.

HOW VOLLEYBALL IS PLAYED

The name “volleyball” is not an entirely accurate description of this sport. The object of the game is hit the ball over the net in such a way that the opposing team cannot return it.

Volleyball is played on a court 30 feet wide by 60 feet long. The net is three feet high and spans the width of the playing area. The top of the net is positioned eight feet (in men's volleyball) from the floor or playing surface. The modern volleyball is about the size of a soccer ball.

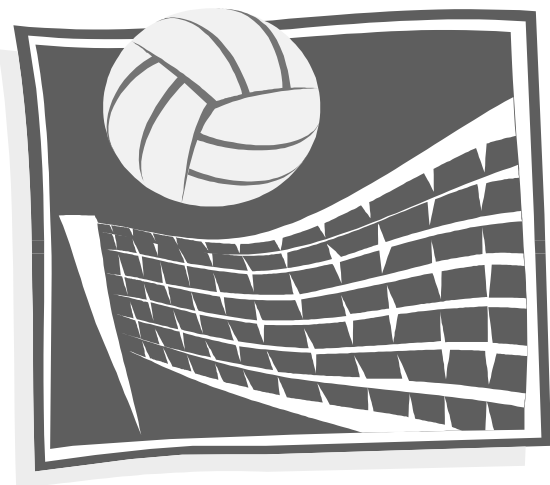

The game is played by two opposing teams, with six players on each team. Once the ball is put into play, it is “volleyed” back and forth between the teammates up to three times before it is hit over the net or until it falls to the floor, is hit out of bounds or a team commits a foul. The same player may not make a hit twice in a row. Even if the ball hits a player by accident, it counts as one of the three touches allowed per side. However, if a player blocks a spike, the block is not considered a “hit.”

VOLLEYBALL SCORING SYSTEMS

RALLY POINT SCORING

The team winning a rally scores a point. When the receiving team wins a rally, it gains a point and the right to serve, and its players rotate one position clockwise. The best of three or best of five games will win matches. Each non-deciding game will be won by the team that first scores 25 points with a minimum two-point advantage. If there is a deciding game, it will be won by the team that first scores 15 points with a minimum two-point advantage.

SIDEOUT SCORING

Only the serving team may score a point, except in the deciding game when rally-point scoring is used. When the receiving team wins a rally, it gains the right to serve (also scoring a point in the deciding game), and its players rotate one position clockwise. Rotation ensures that players play at both the net and the back zone of the court. A team wins a game by scoring 15 points with a two-point advantage



and wins the match by winning the best of three or five games. In the event of a 16-16 tie, the team scoring the 17th point wins a non-deciding game with only a one-point advantage. In a deciding game there is no point cap.

Almost all schools have changed from “Sideout Scoring” to “Rally Point Scoring.” Rally scoring looks very similar to a side-out game, with the main difference being a point scored every time the ball is blown dead.

What constitutes a match when you rally score? Teams will play the best three out of five games. “Game-point” for the first four games will be 25 points. (You must win by two points.) The fifth and deciding game is played to 15. (Again, you must win by 2 points.)

How much time should be allotted for matches that are rally scored? Most three of five rally matches end in three games. The approximate length of time for a game (not including warm-up) is less than 20 minutes. Three-game matches take approximately 60 minutes, while five-game matches take approximately 90 minutes. The nature of volleyball allows games to be substantially shorter when one team is strong and another weak. Rally scoring no longer accommodates long non scoring periods during a game or match.

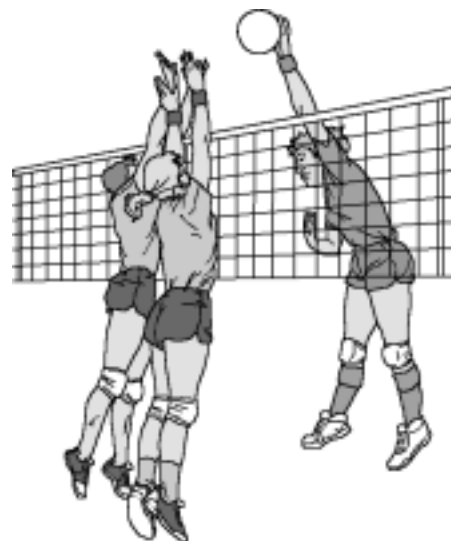

What is the “let serve?” The “let serve” is a ball that when served, hits the net without touching the net antenna and continues across the net into the opponent’s court. The let serve is a playable live ball. The let serve is a strategy used to keep the game moving with fewer interruptions in play.

With the “let serve”, there is no longer a need to touch the net when giving the signal to serve.

Time-outs: Each team is allowed a maximum of two time-outs per game. A time-out is a maximum of 60 seconds, although play may resume sooner if both teams are ready prior to 60 seconds. Extra time-outs are not granted during rally scoring, nor are time-out accumulative during a match.

The game has a total of 15 points. If a team fails to serve properly, return the ball, or commits any other fault, the opponent wins the rally and scores the point. Each game must be won by a two-point margin. A match consists of either three or five 15-point games. The team which wins two (in a three-game match) or three (in a five-game match) games is the winner of the match.



Volleyball requires a referee, who generally has the final word regarding points in dispute, an umpire who assists the referee, a scorekeeper, a timekeeper and linesmen. Even though there may be officials present during a game, players who commit fouls are expected to call out their own mistakes.

SKILLS AND TECHNIQUES

THE READY POSITION AND JUMP

One of the basic positions in volleyball is called the “ready position.” The knees are slightly bent with hands at waist level and elbows near the body to allow the player to concentrate on the ball. Players should learn this position so that time is not wasted when the ball is hit. Jumping is always done near the net. Players should practice jumping so that they do not touch the net, or bump into or injure other players. They should also remember always to jump parallel to the net.

THE SERVE: OVERHAND AND UNDERHAND

Serving is a crucial skill for the volleyball player to learn. The cardinal rules of serving are simple: do not step on a boundary line, and get the ball over the net.

The overhand serve is the most popular and effective serve. It is similar to a tennis serve. The ball is thrown into the air so that it rises a few feet above the server’s head. As the ball comes down, the right arm (if you are right-handed) is raised up and back while the elbow comes forward. The arm is then extended at the elbow and the server hits the ball with the heel of the hand.

The underhand serve is a good serve for beginners to use. It is simply another way of getting the ball over the net. The ball is held in one hand and hit by the heel of the other hand. The underhand serve is generally not as effective as the overhand serve.

THE PASS OR SET



The pass is a difficult move for many beginning players. This skill looks easier than it actually is when performed. Once the ball is served, the player who will pass the ball gets into position under the ball with knees bent, hands up and fingers cupped. All the fingers and the two thumbs contact the ball, but the ball does not touch the palm of the hand.

When the ball is in the air over the serving side's court, it may be passed up to three times before it is returned over the net. One player cannot pass the ball twice in a row.

Note that overhead passes are not used when the returning ball is a "spike."

THE SPIKE

The spike is one of the most difficult plays in volleyball: a player has to run, jump and hit the ball to a specific spot on the other side of the net. However, it is the best offensive move in volleyball, and it should be learned.

Generally, a spiked ball is hit with an open hand. However, unless a player is quite experienced, spiking a ball can sometimes result in the ball going out of bounds or into the net. Remember that practice in timing, jumping and hitting are required to spike correctly. A spiked ball, hit properly, can move up to a hundred miles an hour.

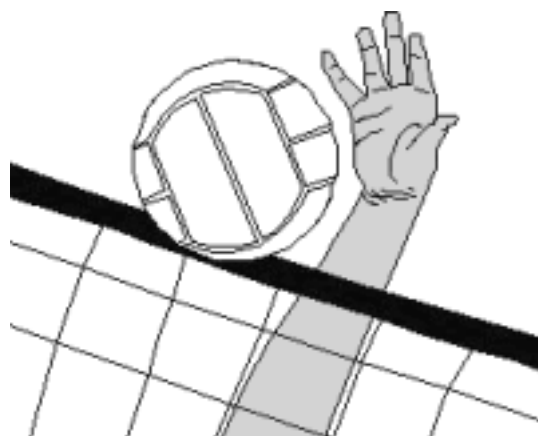

THE FOREARM BOUNCE PASS-BUMP

The bump is used for receiving serves and spike balls. This shot is easy to execute because the ball simply bounces or bumps off the clasped hands, wrists or forearms.

The purpose of this shot is to bounce the ball into the air so that a teammate can get under it to make a set-up (a move usually used to direct the ball to the spiker).

ONE-HAND BOUNCE PASS-DIG

This is a recovery shot, and is used if the ball received is low and off to the side of a player. If you cannot make a bump pass, use a dig or save pass instead. In this move, the hands are cupped. They are then placed under the ball just before it hits the floor.

THE BLOCK

This move is used chiefly as a defensive position to stop spiked balls. As with spiking, timing is important in blocking.



A player must anticipate an opponent's spike and position him or herself accordingly. The blocker then jumps just after the spiker has jumped. The blocker's arms should be extended upward with fingers spread wide apart. This allows the ball to bounce off the heels of the blocker's hands and land on the opposite side of the net.



This is the only move in volleyball that allows the player's hands to go over the top of the net.

EQUIPMENT AND CLOTHING

Standard clothing for playing volleyball is comfortable sportswear which allows for free movement. Gym shoes are a must since most gyms do not allow anyone on the floor in regular shoes. When played on the beach, attire ranges from gym clothes to swimsuits. Many play barefoot in the sand.

VOLLEYBALL NOTES AND NEWS

UCLA swept Penn State in three games to win the 2006 National Collegiate Men's Volleyball Championship, defeating the Nittany Lions 30-27,30-27,30-27. It is the 19th time the Bruins have won the national title in men's volleyball. The Anteaters posted 18 more wins than last year as they entered the NCAA Tournament with a 27-4 record and a No.1 ranking in the CSTV/AVCA Division I-II Men's Coaches poll.

In 2006 Division I women's volleyball, the No. 16 University of Hawai'i Rainbow Wahine volleyball team (15-5) defeated the Notre Dame Fighting Irish (12-7) 30-28, 30-25, 22-30 and 30-23 in front of a crowd of 6,027 at the Stan Sheriff Center, ending their stretch of seven matches in 11 days.

Volleyball is also an Olympic sport. At the 2004 Olympics, both women and men had 12 teams in competition.

Medalists in the 2004 Athens Olympic Indoor and Beach Volleyball competition are listed on the next page.

Indoor Competition:

Men's:

GOLD - BRAZIL
SILVER - ITALY
BRONZE - RUSSIA

Women's:

GOLD - CHINA
SILVER - RUSSIA
BRONZE - CUBA

Beach Competition:

Men's:

GOLD - BRAZIL
SILVER - SPAIN
BRONZE - SWITZERLAND

Women's:

GOLD - UNITED STATES
SILVER - BRAZIL
BRONZE - UNITED STATES



In addition to these national and international contests, local volleyball competitions are held in most states. Check your local schools and volleyball associations for coverage.

You can also find out more by visiting these volleyball web sites on the internet:

<http://www.ncaasports.com/volleyball>

<http://www.volleyball.org>

Name: _____ Date: _____

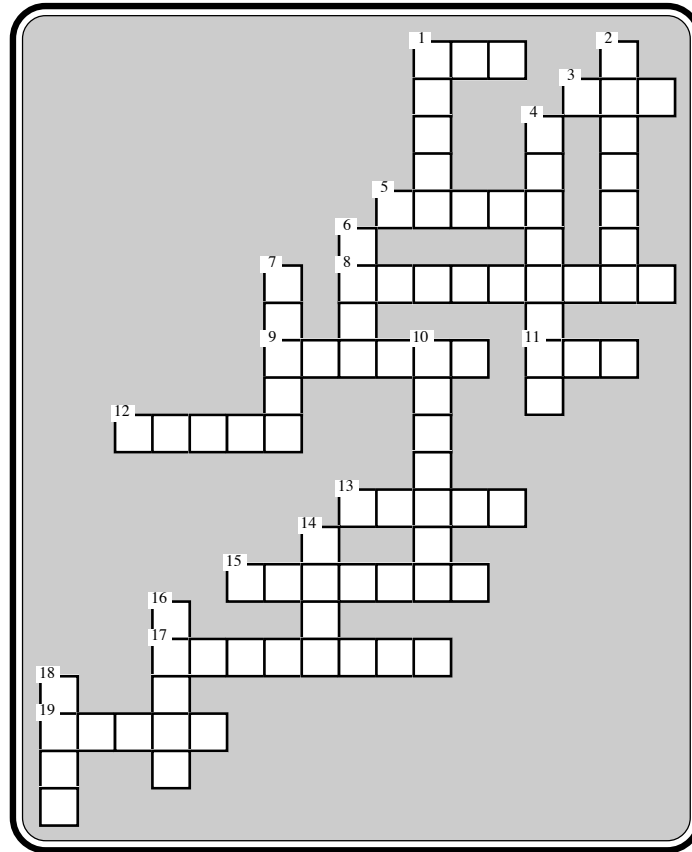

Across:

1. The number of players on a volleyball team
3. A type of forearm pass
5. The ball is put into play when one team does this
8. To serve with the heel of the hand
9. This person assists the referee
11. It is three feet high and is located in the center of the court
12. The top of the net is _____ feet from the floor
13. Most number of times the ball can be volleyed across the net
15. First volleyball was made of this from a basketball
17. They assist the referee
19. Three out of five 15-point games

Down:

1. Fast offensive hit to a specific spot
2. Total points in a game
4. Most popular serve technique
6. The forearm bounce pass- _____
7. It is 30 feet wide and 60 feet long
10. Chief official for a volleyball game
14. The palm does not touch the ball during a _____
16. Defensive technique to stop spiked balls
18. Institution where volleyball was founded

Name: _____ Date: _____

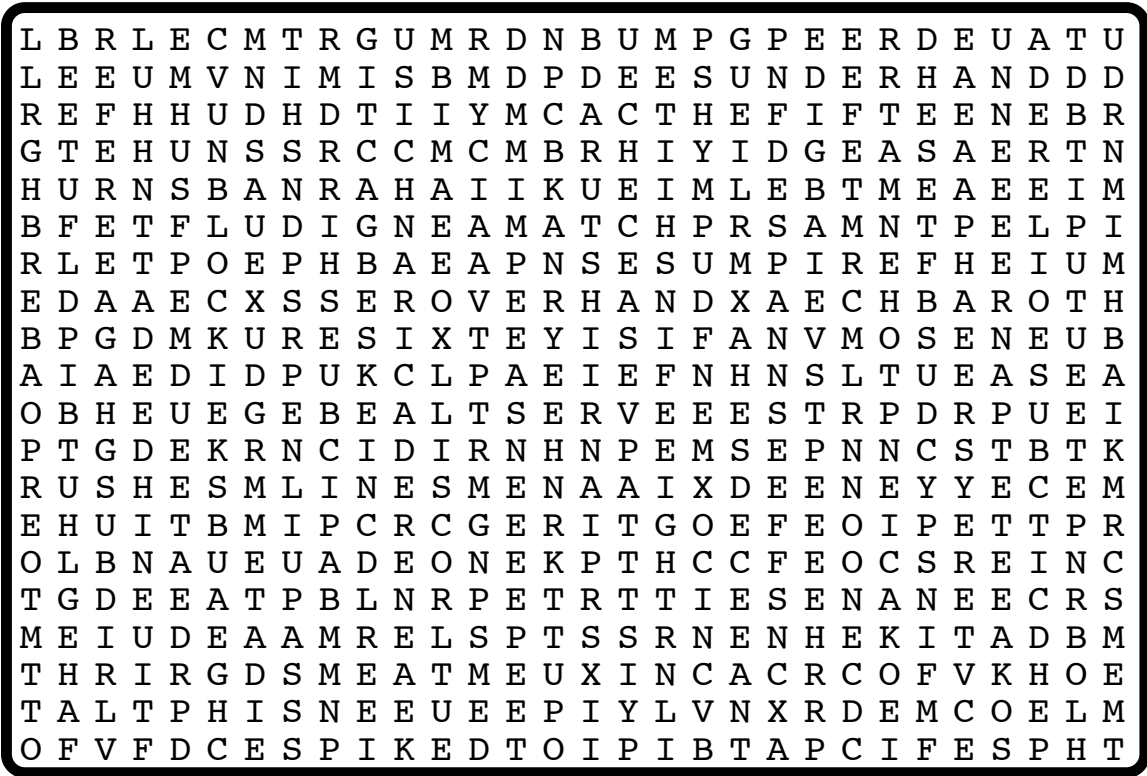

Use the clues below to discover words in the above puzzle. Circle the words.

1. It is 30 feet wide and 60 feet long
2. It is three feet high and is located in the center of the court
3. Defensive technique to stop spiked balls
4. Three out of five 15-point games
5. Most popular serve technique
6. Total points in a game
7. The ball is put into play when one team does this
8. Institution where volleyball was founded
9. The top of the net is ____ feet from the floor
10. Fast offensive hit to a specific spot
11. A type of forearm pass
12. They assist the referee
13. Chief official for a volleyball game
14. First volleyball was a basketball's _____
15. Most number of times the ball can be volleyed across the net
16. To serve with the heel of the hand
17. The number of players on a volleyball team
18. The palm does not touch the ball during a _____
19. The forearm bounce pass-_____
20. This person assists the referee

INSTRUCTIONS

This Learning Packet has two parts: (1) text to read and (2) questions to answer.

The text describes a particular sport or physical activity, and relates its history, rules, playing techniques, scoring, notes and news.

The Response Forms (questions and puzzles) check your understanding and appreciation of the sport or physical activity.

INTRODUCTION

Badminton is a popular and physically demanding game with an interesting history. Like most sports, it requires that players be physically fit and alert. The game demands intense playing time on the court—in fact, games can last anywhere from thirty to ninety minutes.

Badminton is considered a good sport to help build and maintain overall fitness. During an average game, players jump, run, turn and twist in many different directions. In fact, a top-level amateur badminton player runs more in a badminton game than a football end does during a one-hour football game. A badminton player also uses his/her arms more than a pitcher does in the average one and one-half hour baseball game! In short, badminton is great aerobic exercise. It's a fun sport and also is a means to better physical fitness.

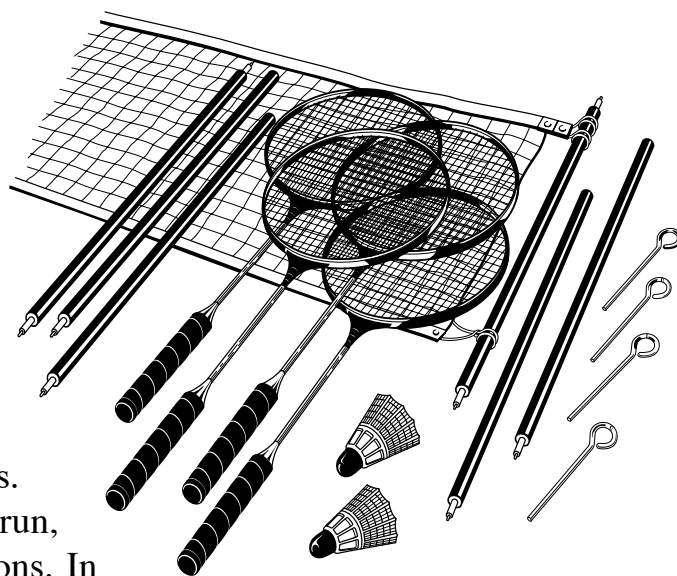

HISTORY OF THE GAME

Badminton is said to have been played centuries ago in China; the earliest written records of the game date back to the twelfth century. However, the game that we know today as badminton was first played in England in 1873 by soldiers returning from military ser-

vice in India. There the game was called “poona.”

In 1903, the first international badminton competition was played in Ireland. The International Badminton Federation (IBF) was founded in 1934. The IBF claims that today, more than 155 countries participate in international badminton competitions. Badminton is not just a local or national activity. It is an Olympic sport.

HOW BADMINTON IS PLAYED

In many ways, badminton is similar to tennis. Once it is determined which player will serve first, play starts from the right service court. A “shuttlecock” or “shuttle” is used instead of a ball.

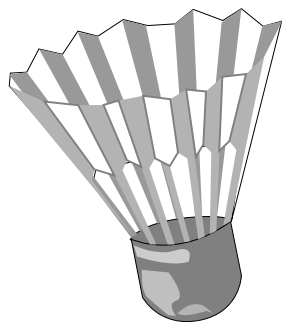

One popular form of shuttle has a cork base with sixteen feathers arranged around the edges. This type of shuttle is light in weight—only one-sixth of an ounce, although it is more expensive than the plastic version. The plastic shuttle is thought to be as effective as the feathered version, is more durable and less expensive.

When served, the shuttle has to fall into the corresponding court diagonally opposite the server. The receiving player then returns the shuttle and continues to do so until one player either fails to return the shuttle or commits a fault.

In badminton, a fault consists of a shuttle falling outside the boundaries, failing to go over the net, and/or going through the net. Striking the shuttle before it crosses the net and touching the net with the racquet or part of the body also qualify as faults.

The server is the only player who can make points. If the server wins the point, he or she continues to serve. However, the second serve then is made from the left side of the court. The serve lasts until the player fails to hit the serve into the proper court or makes a fault. When this happens, the second player serves his/her first service from the right court. The serving player alternates from the right to the left service court until the serve is lost.

The International Badminton Federation’s new scoring rule number 9.3 states that for men’s singles or doubles games if a player (or side) achieves the score 15-0, the game is

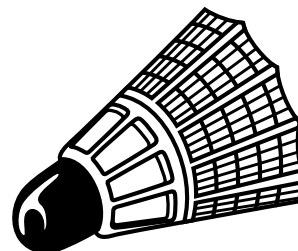
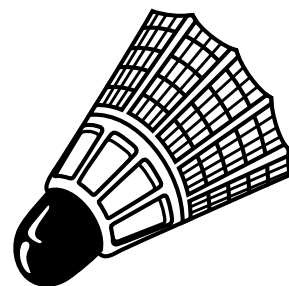

won. A match is considered the best two out of three games. The same rules that apply to singles play also apply to doubles play except for the order of serving and receiving. The IBF scoring rules for women's singles and doubles list 11 points as needed to win a game.

PLAYING TECHNIQUES

FOREHAND/BACKHAND SHOTS

Basic forehand shots are similar to throwing a ball: the hand flexes at the wrist. Basic backhand shots are best described as flicking: the hand extends at the wrist.

Both types of basic shots are best executed when the player is in a ready stance—knees bent, arms at waist level and weight forward.

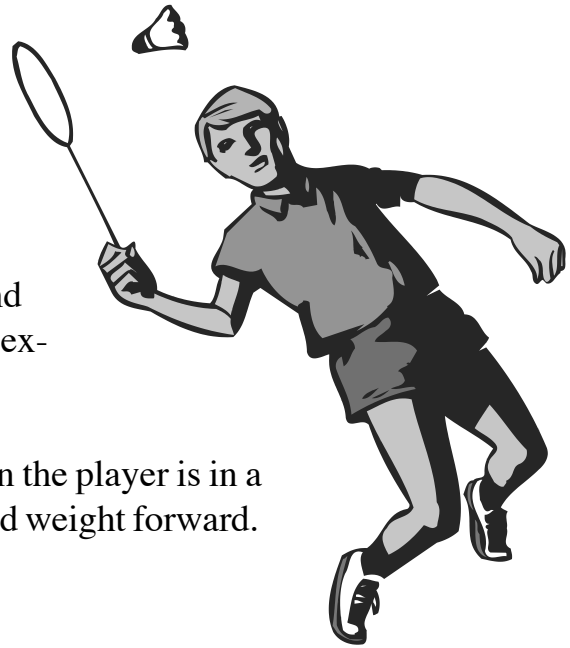

SERVE

The serve is an underhand shot. The racquet head must be below the level of the server's hand while the shuttle is hit below waist level.

It is especially important to follow through the serve by continuing to keep the racquet moving upward after the shuttle is hit. If the racquet does not complete the follow-through, the shuttle may end up in an undesirable location.



SMASH SHOT

This type of shot is considered the ultimate “attacking” shot and requires a powerful arm stroke. It can be played from anywhere on the court, although it is usually played between the doubles back and the front service lines.

CLEAR

This unusual defensive stroke is employed in singles and generally used sparingly. The object is to hit the shuttle high and deep to the opponent's back court. This shot is played well behind the shuttle. The point of impact is directly above or slightly behind the head.

The arm moves straight up as racquet head and shuttle meet.

DROP

This shot is sometimes referred to as a “controlled smash” shot. It differs from the smash because it is hit with less force. The drop is considered a sure way to score a point when the opponent is out of position. To execute this shot, the player must use the same motion as with any overhand stroke except that he/she tilts the racquet head slightly to cause the shuttle to move downward.

FOREHAND DRIVE

This shot is used when the shuttle is too low to smash. The forehand drive is hit hard with the full racquet face slightly in front of the body at full arm’s length.

FOREHAND UNDERARM CLEAR

This can be a tricky shot. It is best described as hitting a high serve, only lower down. The player lunges forward with the front knee bent and the back leg slightly bent while he/she leans toward the shuttle.



BACKHAND DROP

The overhand backhand shot is performed the same way that the clear and smash are played. This shot demands both excellent timing and wrist-snap action.

EQUIPMENT AND CLOTHING

The equipment needed to play badminton is simple. Aside from the regulation court (22 feet in length by 17 feet in width) and net, badminton requires only a racquet and shuttlecock. The badminton racquet resembles a tennis racquet, although it is lighter in weight—usually between three and five ounces. Most contemporary players prefer metal racquets over wooden ones.

Clothing is similar to that worn by tennis players: light polo shirts or blouses are worn to provide freedom of movement. Footwear should provide good support and an adequate grip on the surface of the court.

BADMINTON NOTES AND NEWS

The 2006 International Badminton Federation World Championships (15th tournament) were held in Madrid, Spain (September, 2006). The results:

Men's Singles

Gold- Lin Dan (China)

Silver- Chunlai Bao

Women's Singles

Gold- Xie Xingfang (China)

Silver- Ning Zhang (China)

Men's Doubles

Gold- Fu Haifeng and Cai Yun (China)

Silver- Anthony Clark and Robert Blair (England)

Women's Doubles

Gold- Gao Ling and Huang Sue (China)

Silver- Yawen Zhang and Yili Wei (China)

Mixed Doubles

Gold- Nathan Robertson and Gail Emms (England)

Silver- Anthony Clark and Domsna Kellogg (England)

Badminton is also an Olympic sport. The top two finishers in each group at the Athens Olympic competition in 2004 are listed below.

Men's Singles

1. TAUFIK HIDAYAT (INDONESIA)
2. SHON SEUNG-MO (SOUTH KOREA)

Women's Singles

1. ZHANG NING (CHINA)
2. MIA AUDINA TJIPTAWAN (NETHERLANDS)

Men's Doubles

1. SOUTH KOREA
2. SOUTH KOREA

Women's Doubles

1. CHINA
2. CHINA

Find out more by visiting these badminton web sites on the internet:

<http://www.badminton.ca/>

<http://www.usabadminton.org/>

STUDENT RESPONSE PACKET

BADMINTON

NAME _____

DATE _____

WHAT TO DO

The following questions will help you to have a greater appreciation and understanding of badminton. Write your answers in the spaces below the questions. If there is not enough room, write on the backs of these sheets. Be neat, spell correctly, and write in complete sentences.

1. Why is badminton a good game to help maintain and improve physical fitness?
2. What equipment is needed to play badminton?
3. Who can make points in a badminton game?
4. How is a badminton game won?

Name: _____ Date: _____

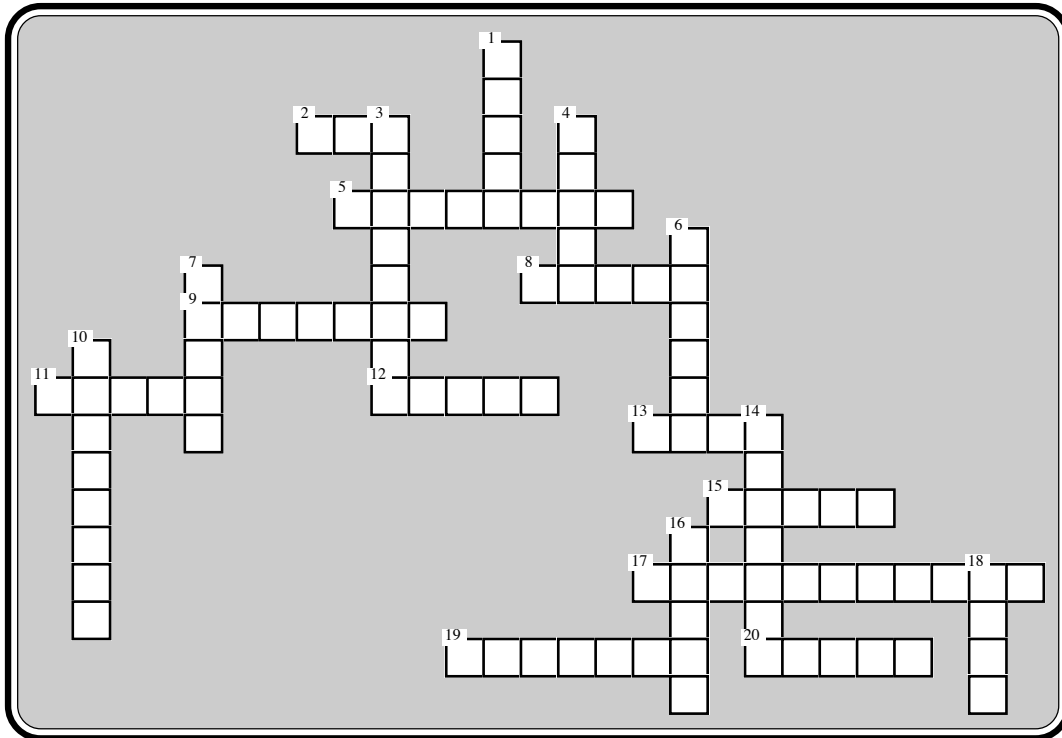

Across:

- 2. Acronym for badminton federation founded in 1934
- 5. Done with a “flicking” motion
- 8. This is always an underhand shot
- 9. A badminton racquet is _____ than a tennis racquet
- 11. Name of badminton played by British in India
- 12. The ultimate attacking shot
- 13. A controlled smash
- 15. When a shuttlecock falls out of bounds
- 17. What you hit in badminton
- 19. Number of points needed to win a game
- 20. This is 22 feet long and 17 feet wide

Down:

- 1. Best of three games
- 3. Vanes used to be made of them
- 4. A shuttlecock weighs one-sixth of one
- 6. The only player who can score a point
- 7. A rarely used high and deep defensive stroke
- 10. Motion similar to throwing a ball
- 14. Shuttlecocks are now made of this
- 16. Where badminton was played hundreds of years ago
- 18. The traditional shuttlecock base was made of this material

Name: _____ Date: _____



Use the clues below to discover words in the above puzzle. Circle the words.

1. A rarely used high and deep defensive stroke
2. This is always an underhand shot
3. A badminton racquet is _____ than a tennis racquet
4. Motion similar to throwing a ball
5. Acronym for badminton federation founded in 1934
6. Where badminton was played hundreds of years ago
7. The ultimate attacking shot
8. Vanes used to be made of them
9. Shuttlecocks are now made of this
10. The traditional shuttlecock base was made of this
11. When a shuttlecock falls out of bounds
12. Done with a “flicking” motion
13. A controlled smash
14. This is 22 feet long and 17 feet wide
15. Best of three games
16. Number of points needed to win a game
17. The only player who can score a point
18. What you hit in badminton
19. A shuttlecock weighs one-sixth of one
20. Name of badminton played by British in India

INSTRUCTIONS

This Learning Packet has two parts: (1) text to read and (2) questions to answer.

The text describes a particular sport or physical activity, and relates its history, rules, playing techniques, scoring, notes and news.

The Response Forms (questions and puzzles) check your understanding and appreciation of the sport or physical activity.

INTRODUCTION

Tennis is among the most popular sports in the United States. It is played by amateurs and professionals, children and adults, women and men. It can be played for sheer enjoyment or in fiercely competitive tournaments, such as the famous Davis Cup, Wightman Cup and the Wimbledon tournament. Like badminton, it requires agility, speed and almost continuous motion on the part of the player. It is often recommended as a good means of aerobic exercise.

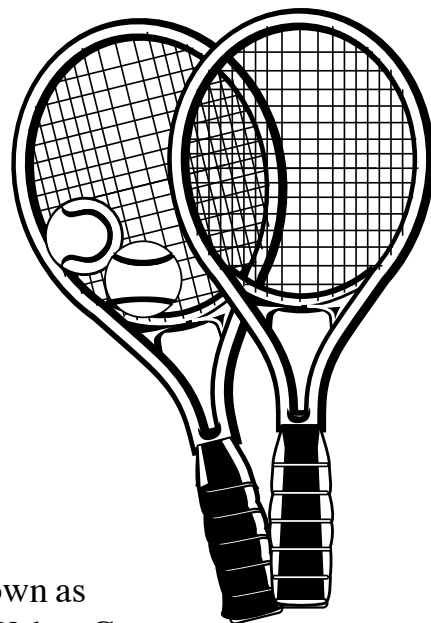

HISTORY OF TENNIS

The game that we know as “tennis” today (officially known as “lawn tennis”) was created by a British citizen, Major Walter C. Wingfield, who introduced the game to Britain in 1873. The following year saw the introduction of the already-popular game to America.

However, the real history of tennis apparently goes back far beyond Major Wingfield’s day. A version of tennis was played in ancient Greece and in France in the 1400s.

The first tennis tournament was played at Wimbledon in England in 1877. While Wimbledon is still considered the most famous and prestigious tennis tournament in the

world, the Davis Cup and Wightman Cup tournaments are also important annual events.

HOW THE GAME IS PLAYED

A tennis game always starts with the serve. The server stands behind the base line on the right side of the court. The ball is tossed into the air and hit diagonally across the net into the opponent's court. The opponent then has to hit the ball after the first bounce, and return it back across the net to the server.

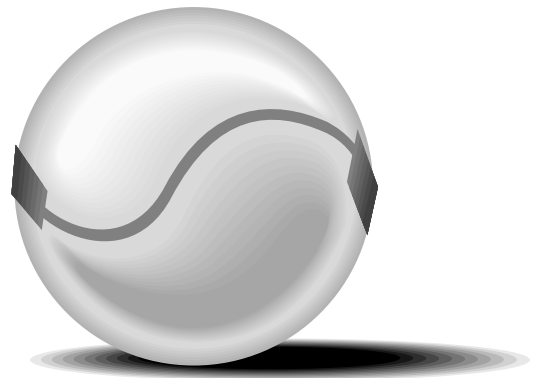

The opponent then has to hit the ball after the first bounce, and return it back across the net to the server.

A “fault” is committed when the server hits the net with the ball or when the ball is hit outside the service court. The second time a server tries to serve and fails, “a double fault” occurs. The opponent automatically gains a point after a double fault.

Faults can also occur when the server touches the base line or any other part of the court with his/her feet while serving.

A “let ball” is a serve that touches the net but lands in the correct place. This type of ball does not count; the server must serve again.

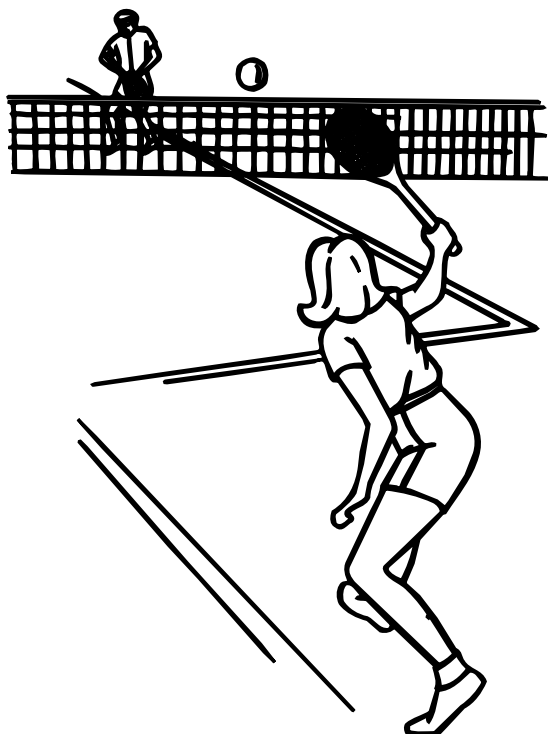

A ball that touches the net during play is called a “net ball.” Net balls are legal and must be played.

Once the first point is made, the server then serves from behind the left base line. The server continues until the opponent wins the serve or until a fault occurs.

The first point in a tennis game is 15, the second is 30 and the third is 40. The final score (or fourth point) is the GAME POINT.

A player must score four points in order to win a game. In a tie game, both sides or players may score three points, or 40-40 (a ‘DEUCE’). If a player or side wins two more points after a deuce, the game is won.

The “AD” or ADVANTAGE is the first point scored after the deuce. When both players score a point after a deuce, the game returns to 40-40 again.

The score “LOVE” means zero. If a game has the score 30-love, it means the score is 30 to zero. Nobody knows why the term “love” is used in tennis, but it is generally believed to have originated from the French word “l’ouve,” which means “egg.” An egg is round like a circle, hence its association with a zero.

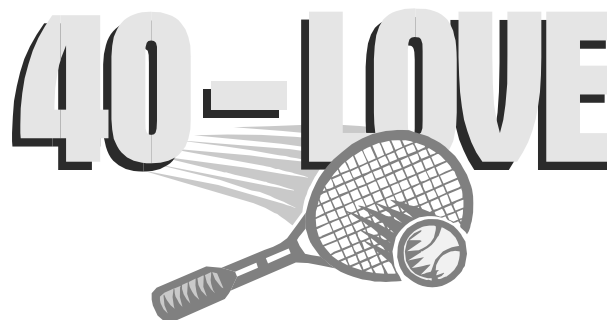

A SET means that one side or player has won six games. The winner of the set must win by two games. A MATCH means that two out of three sets have been won.

PLAYING TECHNIQUES

THE SERVE



There are four types of serves in tennis: the flat serve, the slice serve, the kick serve and the American twist. While the slice is the most common and effective serve, all four types of serves demand a controlled toss and good follow-through.

To execute the serve properly, the player raises the racquet back to a point where it reaches over his or her right shoulder. The player’s elbow is kept straight in the air. The proper stance is straight, not bent at the waist. The ball is then tossed up into the air. As the ball comes down, the server moves forward and strikes the ball with the racquet, driving it over the net toward the other player or players.

FOREHAND DRIVE

This move is one of the two main strokes used for returning the ball after one bounce. When the ball approaches the player’s racquet-hand side, the forehand drive is used—basically, as a way of blocking the ball. The wrist maintains a firm position and keeps the racquet face open. All contact with the ball should take place in front of the player’s body.

BACKHAND DRIVE

This move is the other main stroke used to return a ball after one bounce. In the backhand drive, the ball goes to the opposite side of the racquet hand. The player moves the arm across the body and, as with the forehand drive, maintains a firm wrist and elbow. Again, contact with the ball is made in front of the player's body.

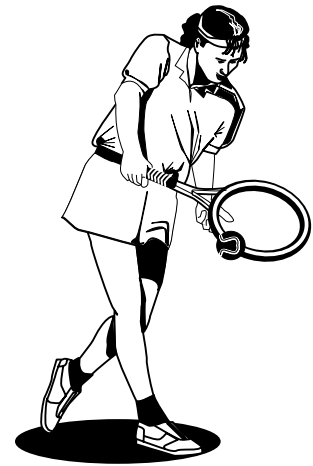

VOLLEY

The famous Martina Navratilova once offered this advice about the volley: "Keep it short and simple." The player's knees should be bent and legs slightly apart while the weight of the body is forward. The elbows should be turned in toward the body as the body pivots and the shoulder turns toward the ball.

The power of the volley comes not from the swing, but from a firm wrist, good timing and the ability to keep one's body weight forward.

LOB

The lob features a short backswing, an open racquet face and an upward motion. The follow-through on this shot is shorter than on other shots. The goal of the lob is to hit the ball over the opponent's head in order to drive him/her back in the court.

SLICE



The forehand and backhand slices are used to make the ball spin and bounce crookedly. In the forehand slice, the player's shoulders should turn as the racquet is brought back above the level of the ball. The racquet head is tilted upward at this point, while the player's weight is kept forward. Ideally, the follow-through on this shot is kept short.

In the backhand slice, the player turns as the racquet is brought back above the level of the ball. The wrist is kept stiff as contact with the ball occurs in front of the player's body.

EQUIPMENT AND CLOTHING

Tennis is usually played in loose-fitting shorts for men or short skirts for women. Athletic shoes are needed to brace the feet and ankles during violent maneuvers. Light polo shirts or blouses are worn to provide freedom of movement.

TENNIS NOTES AND NEWS



Amelie Mauresmo defeated Justine Henin-Hardenne (2-6, 6-3, 6-4) to win the Wimbledon championship in 2006. The victory was especially sweet because Mauresmo's last grand slam victory came in January 2006 when Henin-Hardenne withdrew because of stomach cramps. This time she can revel in the glory of a hard-earned victory.

Mauresmo made a terrible start, dropping the first set in 31 minutes, but then it was Henin-Hardenne's turn to falter.

Mauresmo took the final into a decider and despite several nerve-racking moments, held on for an emotional win.

The Frenchwoman, so often accused of choking on the big occasion, dropped to her knees and burst into tears as the reality of her victory sank in.

"I definitely wanted this win today and I don't want anybody to talk about my nerves anymore," she joked in an on-court interview. "This trophy is so special in the world of tennis and it feels great."

Roger Federer wrapped up his fourth consecutive Wimbledon title in 2006 by subduing Spain's Rafael Nadal 6-0, 7-6, 6-7, 6-3.

It looked as though the world number one would run away with an eighth grand slam title after rampaging through the first set in 24 minutes before double French Open champion Nadal recovered to make the Swiss maestro sweat on a breezy Centre Court.



Federer dropped a set for the first time at this year's tournament as the 20-year-old Nadal refused to surrender, but in the end he had enough grasscourt craft to become only the

third man to win four straight titles here in the professional era.

“It’s fantastic, I never thought it was possible but I made it,” Federer, clad in his cream blazer, said in his acceptance speech after an enthralling two hour 50 minute contest. “It was awfully tight and I was getting awfully nervous in the end.”

Athens 2004 Olympic Results:

Men’s Singles:

Gold: Nicolas Massu, Chile
Silver: Mardy Fish, United States
Bronze: Fernando Gonzalez, Chile

Women’s Singles:

Gold: Justine Henin Hardenne, Belgium
Silver: Amelie Mauresmo, France
Bronze: Alicia Molik, Australia

Men’s Doubles:

Gold: Fernando Gonzalez and Nicolas Massu, Chile
Silver: Nicolas Kiefer and Rainer Schuettler, Germany
Bronze: Mario Ancic and Ivan Ljubicic, Croatia

Women’s Doubles:

Gold: Li Ting and Sun Tian Tian, China
Silver: Conchita Martinez and Virginia Ruano Pascual, Spain
Bronze: Paola Suarez and Patricia Tarabini

Keep current with the sport of tennis by visiting these tennis websites:

<http://www.atptour.com/>

<http://www.ncaasports.com/>

<http://www.tennisserver.com/>

<http://www.tennis.com>

STUDENT RESPONSE PACKET

TENNIS

NAME _____

DATE _____

WHAT TO DO

The following questions will help you to have a greater appreciation and understanding of tennis. Write your answers in the spaces below the questions. If there is not enough room, write on the backs of these sheets. Be neat, spell correctly, and write in complete sentences.

1. What are the physical benefits of playing tennis?

2. What is "a fault" in tennis?

3. What is a "let ball?" a "net ball?"

4. When and where was tennis first played?

5. Name the four types of serves in tennis.

6. What is the tennis volley and how is it executed?

7. What does the score “love” mean in tennis?

8. What does “a set” in tennis mean?

9. What is the first point in a tennis score?

10. What comprises “a match” in tennis?

Name: _____ Date: _____

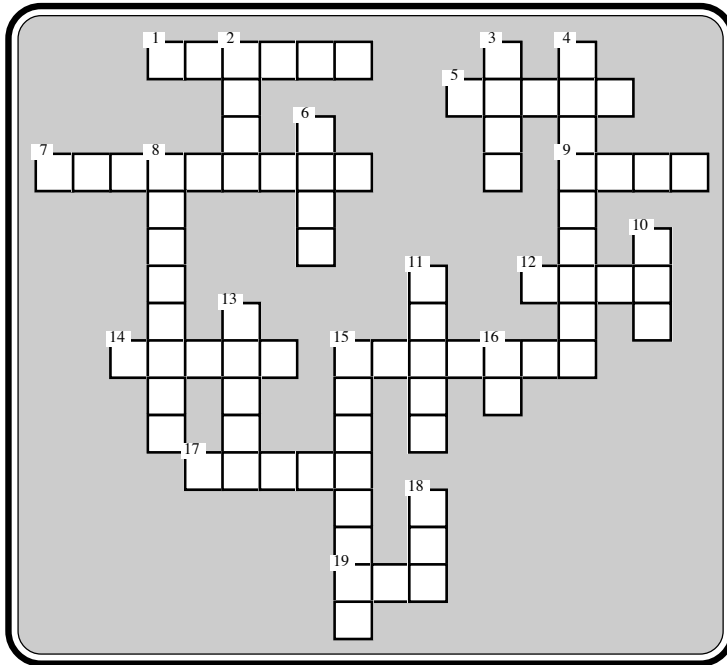

Across:

- 1. Martina says keep it short and simple
- 5. A popular tennis tournament
- 7. Most famous tennis tournament
- 9. One must win at least six of these to win the set
- 12. Love in tennis means this for a score
- 14. When the server hits the net with the ball
- 15. The direction of the player's weight when hitting a slice
- 17. A score of 40-40
- 19. It is in the middle of the court and the ball must be hit over it

Down:

- 2. Comes from the French word for "egg"
- 3. Tennis was originally played on this
- 4. This major introduced tennis to England in 1873
- 6. There are this many types of serves in tennis
- 8. One type of drive
- 10. Short backswing and upward motion
- 11. A tennis game starts with one of these
- 13. Makes the ball bounce and spin
- 15. Another type of drive
- 16. The first point scored after deuce
- 18. The server hits the net with the ball and the ball lands in the right place

Name: _____ Date: _____

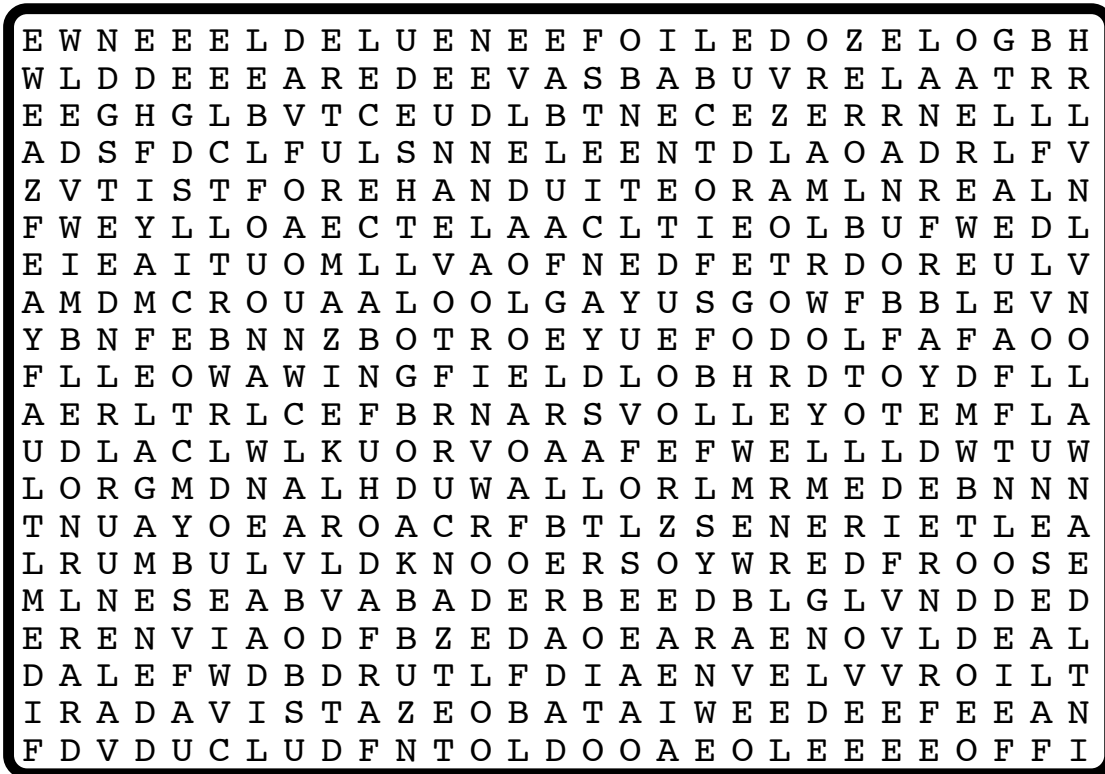

Use the clues below to discover words in the above puzzle. Circle the words.

1. One type of drive
2. Another type of drive
3. A tennis game starts with one of these
4. One must win at least six of these to win the set
5. Tennis was originally played on this
6. The server hits the net with the ball and the ball lands in the right place
7. When the server hits the net with the ball
8. Comes from the French word for "egg"
9. A score of 40-40
10. Short backswing and upward motion
11. Makes the ball bounce and spin
12. Love in tennis means this for a score
13. This major introduced tennis to England in 1873
14. Martina says keep it short and simple
15. Famous tennis tournament
16. The direction of the player's weight when hitting a slice
17. Most famous tennis tournament
18. The first point scored after deuce
19. There are this many types of serves in tennis
20. It is in the middle of the court and the ball must be hit over it

INSTRUCTIONS

This Learning Packet has two parts: (1) text to read and (2) questions to answer.

The text describes a particular sport or physical activity, and relates its history, rules, playing techniques, scoring, notes and news.

The Response Forms (questions and puzzles) check your understanding and appreciation of the sport or physical activity.

INTRODUCTION

Basketball is an extremely popular sport. More people watch basketball than any other sport in the United States. It is played in driveways, parking lots, back yards, streets, high schools, colleges and professional arenas.

Basketball's popularity is not confined to the United States. The game is also enjoyed internationally, with rules available in thirty languages. Basketball is included among the Olympic sports.

HISTORY OF THE GAME

In 1891, a physical education instructor at a YMCA Training School in Massachusetts invented basketball as an indoor activity for boys. The game began with two peach baskets tied to balconies and a soccer ball used to shoot baskets. Two years later, two college teams began to play basketball. The game's popularity has increased continuously ever since.

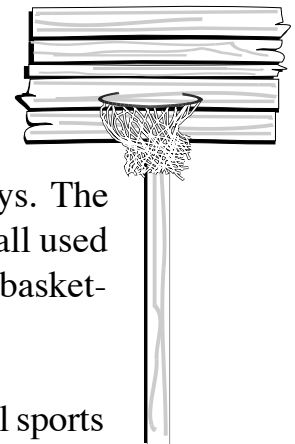

The National Basketball Association (NBA) is the largest professional sports league. It was created when the Basketball Association of America and the National Basketball League merged in 1949. The majority of professional players are recruited by the NBA from college ranks.

HOW THE GAME IS PLAYED

GENERAL PLAYING RULES

The game of basketball is easy to understand. Players try to prevent their opponents

from scoring while each team tries to get the ball through the basket that the other team is defending. Although the game is not difficult to understand, a tremendous amount of mental and physical endurance and skill is required from the five players on each team.

A basketball team consists of a center, two forwards and two guards. The forwards are positioned near the opposing team's basket so that they can be ready for shooting and rebounding. The center is located near the basket or near the free-throw line so that he/she can be ready for shooting and rebounding. Guards normally bring the ball down the court to begin offensive play.

The game begins with a jump ball. The referee tosses the ball into the air. As it comes down, one player from each team jumps upward in an attempt to tap the ball to a teammate. Once the ball is in play, team members dribble the ball in order to get closer to the basket or pass it to another player. "Dribbling" the ball means bouncing it on the floor repeatedly with one hand. "Passing" means throwing the ball to a teammate. Passing is vital to scoring plays. In fact, most professionals consider good passing to be almost as important as accurate shooting.

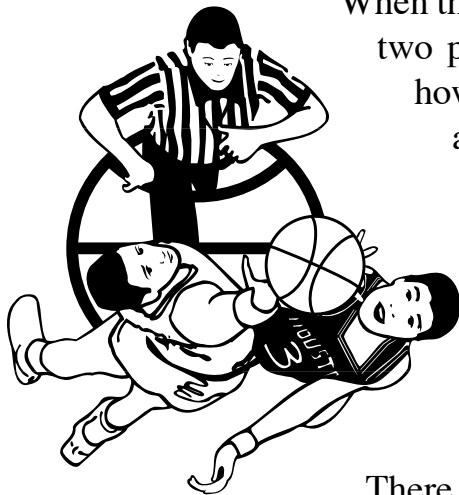
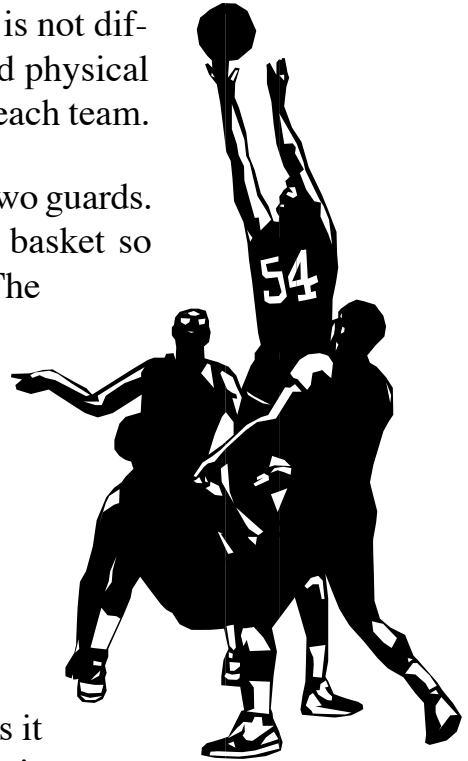

When the ball is put into the basket, it is called a "field goal" and two points are awarded to the team that scores. If the shot, however, was taken past the three-point line, then three points are earned. The National Basketball Association instituted a new distance of 20'-6" from the basket for the 3-point line. A "free throw" means a toss from behind the free-throw line, with no interference from the opposing team. If a player has been fouled by an opponent, the fouled player gets a free throw. If the free throw ball goes into the basket, the team gets one point.

There are two types of fouls in basketball—personal fouls and technical fouls:

A personal foul means that a player holds, pushes or trips an opponent.

A technical foul may occur when the game is delayed, too many time-outs are taken, players leave or enter the court illegally or participate in misbehavior such as disrespect toward the referee.

A team may lose possession of the ball for “traveling.” Traveling occurs when a player runs or walks with the ball. Double dribbling (bouncing the ball with both hands or stopping dribbling, then starting again) can also cause a team to lose possession of the ball.

DEFENSE AND OFFENSE

Professional basketball teams play four 12-minute quarters. College-level play amounts to two 20-minute halves, and high school basketball is four 8-minute quarters. In the case of a tie game, teams play overtime.

Professional teams play 5-minute overtimes. High school and college teams play shorter overtimes.

DEFENSE

The zone and player-to-player (once called “man-to-man”) systems are two defensive techniques. The zone system uses each player as a guard, protecting a specific zone near the basket that his/her team is defending. Guarding the ball is more important than any particular player in this type of defense.

In the player-to-player (“man-to-man”) system, the opposite is true. Each player guards a player from the opposing team in order to keep the opposition from scoring.

OFFENSE

The fast-break offensive style offers fast movement from one part of the court to another and a chance for scoring. It is characterized by fast, quick passes down the court and using more players on the attack than the opposition has for their defense.

Slower, more deliberate play characterizes the slow-break style. This technique calls for more thoughtful action; players maneuver carefully in order to shoot in this type of offense.

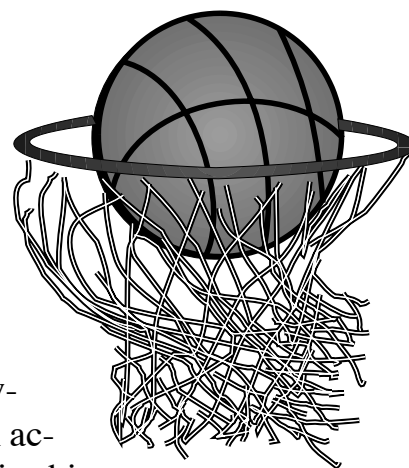

PLAYING TECHNIQUES

TYPES OF SHOTS

ONE-HAND SHOT

A shot executed with both hands holding the ball initially. The ball is then pushed into the basket with one hand.

HOOK SHOT

The ball is thrown to the basket over one shoulder of the player who is handling the ball. The center and forwards on a team will find this shot extremely valuable.

TWO-HANDED SHOT

A shot usually made when a player is not close to the basket. The ball is thrown with two hands. This type of shot tends to be quite accurate.

JUMP SHOT

A shot in which the player shoots the ball into the basket at the top of the jump.

LAY-UP

A shot in which a basket is attempted from under the net; generally considered one of the easier shots.

TIP-IN

A shot in which the ball is tapped back into the basket as it rebounds from the backboard.

FREE-THROW

A shot in which a player who has been fouled shoots from behind the free-throw line.



BASIC PASSES

TWO-HANDED CHEST PASS

A pass used for short, fast passing of distances up to twenty feet.

TWO-HANDED OVERHEAD PASS

A popular pass that can be used from anywhere on the court; especially good for closely-guarded players.

ONE-HANDED OVERHEAD PASS

A pass used as a long pass from any position on the court. Like all one-hand passes, this move takes more time to perform and requires excellent control.

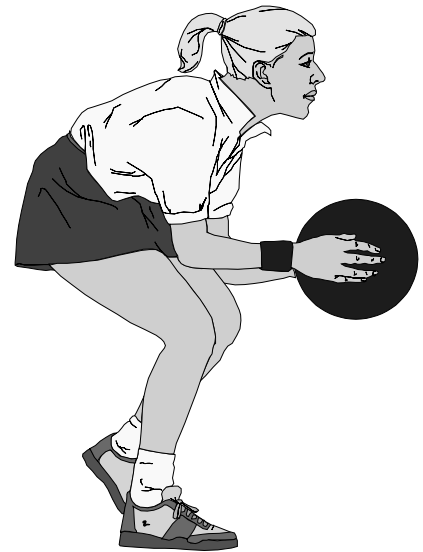

BOUNCE PASS

This pass is used when two players are relatively close to each other. The ball usually bounces once before being caught by the other player.

ONE-HAND UNDERHAND PASS

An effective move when the passer is moving at fast speeds; difficult to perform and should be used only when no alternative exists.

EQUIPMENT AND CLOTHING

A basketball is about two and a half feet in circumference and weighs 22 ounces. Baskets are made of a metal ring with an inside diameter of 18 inches. Netting or webbing hangs from the ring. Two baskets, one at each end of the court, hang 10 feet above the floor. The standard basketball court measures about 50 feet by 94 feet.

Clothing is loose-fitting and designed for freedom of movement. Contemporary “long shorts” were made popular by superstar Michael Jordan of the Chicago Bulls. Shoes are

specially designed to withstand pounding the floor in jumps and other movements, as well as to brace the feet and ankles during violent lateral movements.

BASKETBALL NOTES AND NEWS



In a decisive Game 6 that capped one of the most stunning turnarounds in NBA Finals history, the Heat finished off the Dallas Mavericks and showed themselves to be worthy of being crowned 2006 NBA champions by riding their young superstar, Dwyane Wade, to the first title in franchise history with a 95-92 victory.

Wade didn't quite score 40 this time, as he had twice before in this series, but he came awful close with 36 points and avoided a nightmare finish after blowing a pair of free throws with 9.1 seconds left to give the Mavericks one final chance.

But that chance ended with Jason Terry's 3-point attempt bouncing high and hard off the rim, Wade getting the rebound with a second left and no Mavericks anywhere near him. He tossed the ball high in the air and the Heat players bounded off the bench in celebration, so many years of waiting for so many of them finally having come to an end.

"I don't want to say I put the team on my back. You know, we did it together. Like Coach said, like we've all been saying, it's been 15 strong," Wade said. "They gave me the opportunity by putting the ball in my hands to prove people wrong. When I came into the series, it was, I can't shoot. I don't know where they got that from. So I proved to them I can shoot, and then after that, I proved I can play, and that's all I tried to do: prove people wrong."



Miami became just the third team in NBA Finals history to win a series after dropping the first two games, and the first to do it after losing Games 1 and 2 by double-digit margins. This series actually looked lost for the Heat with 6 minutes left in Game 3 when they trailed by 13 on their home court, but the Mavericks relaxed too soon and never got their groove back, earning the dubious distinction of becoming the first team to lose the NBA Finals in the fourth quarter of a Game.

2004 Athens Olympics Results:

Women:

Gold: United States

Silver: Australia

Bronze: Russia

Men:

Gold: Argentina

Silver: Italy

Bronze: United States

More information about the sport of basketball can be found at these websites:

<http://www.nba.com/>

<http://www.ncaasports.com/>

<http://www.wnba.com/>

STUDENT RESPONSE PACKET

BASKETBALL

NAME _____

DATE _____

WHAT TO DO

The following questions will help you to have a greater appreciation and understanding of basketball. Write your answers in the spaces below the questions. If there is not enough room, write on the backs of these sheets. Be neat, spell correctly, and write in complete sentences.

1. What are some of the physical benefits of playing basketball?
2. True or False: More people watch basketball than any other sport in the United States.
3. What is the object in any game of basketball?
4. What comprises a team in basketball? How many players and what positions?

5. How does any game of basketball begin?

6. What is a field goal?

7. Name at least three types of shots.

8. Name at least three types of passes.

9. Name two defense techniques.

10. What is the difference between a fast-break and slow-break offensive style?

Name: _____ Date: _____

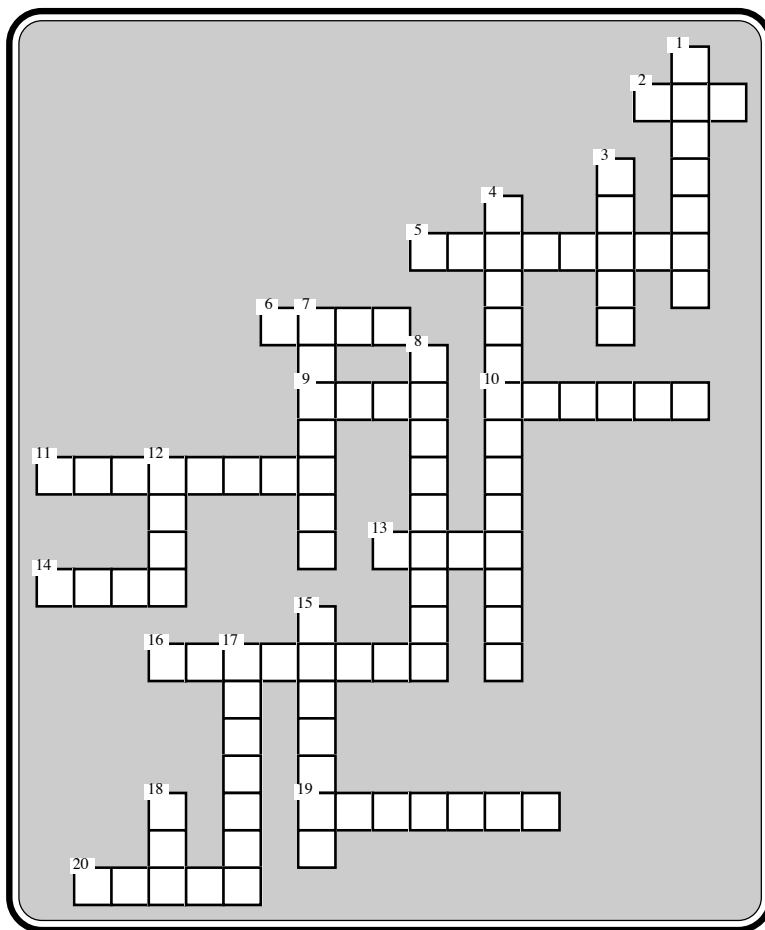

Across:

2. Height in feet of the basket above the floor
5. A professional game is made up of four of these
6. A defensive technique that uses each player to guard a specific area
9. A ____ throw is worth one point if it goes in the basket
10. One of the five players - usually the tallest
11. Inside diameter in inches of a basketball rim
13. Number of players on a basketball team
14. A player's hand is above the rim when the ball is slammed through the hoop
16. One of the two types of fouls
19. This person controls the game by calling the fouls and determining who gets the ball
20. A basketball team usually has two of these (shorter) players

Down:

1. You are on _____ when the other team has the ball
3. A _____ goal is when a player shoots the ball into the basket for two or three points
4. State in which basketball was invented
7. You are on _____ when your team has the ball
8. This type of foul can be called on a player for bad conduct
12. A type of shot where the ball is thrown over one shoulder
15. There are usually two of these players on the team - often good at rebounding
17. When one grabs the ball after a missed shot
18. Acronym for the world's largest basketball association

Name: _____ Date: _____

Physical Education 4 Word Search

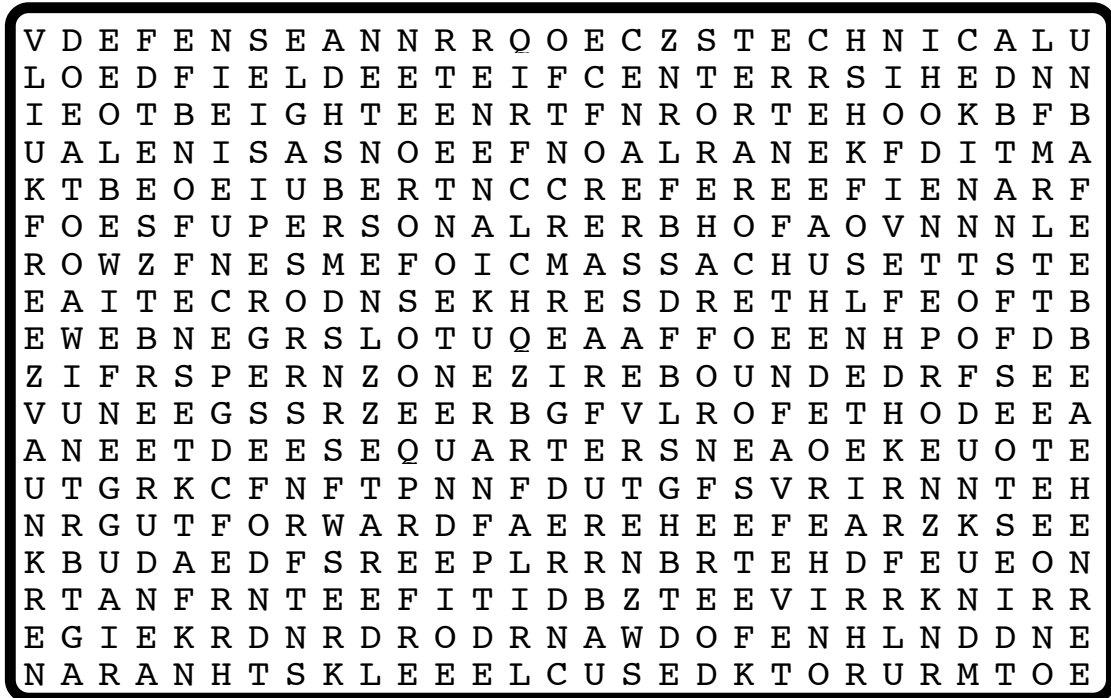

Use the clues below to discover words in the above puzzle. Circle the words.

1. One of the five players - usually the tallest
2. Acronym for the world's largest basketball association
3. A basketball team usually has two of these shorter players
4. There are usually two of these players on the team
5. One person jumps so high his hand is above the rim when he slams the ball through the hoop
6. You are on _____ when the other team has the ball
7. When one grabs the ball after a missed shot
8. A type of shot where the ball is thrown over one shoulder
9. A _____ goal is when a player shoots the ball into the basket for two or three points
10. A _____ throw is worth one point if it goes in the basket
11. You are on _____ when your team has the ball
12. Inside diameter in inches of a basketball rim
13. State in which basketball was invented
14. This type of foul can be called on a player for bad conduct
15. A professional game is made up of four of these
16. One of the two types of fouls
17. Number of players on a basketball team
18. Height in feet of the basket above the floor
19. A defensive technique that uses each player to guard a specific area
20. This person controls the game by calling the fouls and determining who gets the ball

INSTRUCTIONS

This Learning Packet has two parts: (1) text to read and (2) questions to answer.

The text describes a particular sport or physical activity, and relates its history, rules, playing techniques, scoring, notes and news.

The Response Forms (questions and puzzles) check your understanding and appreciation of the sport or physical activity.

INTRODUCTION

Persons of every age and level of skill can enjoy bowling. Even persons with physical disabilities can bowl by using various kinds of adaptors made specifically for them.

Bowling is truly a democratic sport—one that almost everyone can learn to play and enjoy. It's a good way to socialize, exercise and compete all at the same time!

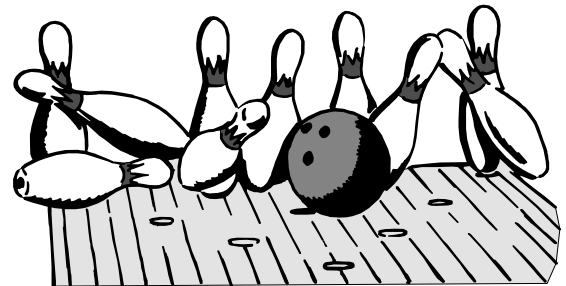

HISTORY OF THE GAME

The history of bowling can be traced back at least seven thousand years. The ancient Egyptians enjoyed a version of the game, as indicated by bowling balls and pins found buried in an Egyptian child's grave.

By the 1840s, bowling had become popular in America. The first indoor bowling lanes were built in New York. Abraham Lincoln was among the many famous Americans who enjoyed bowling.

The American Bowling Conference (ABC) was founded



for men in 1895. A women's organization, the WIBA, was founded in 1916. The two organizations now work together to develop and enforce the rules of the game. The combined membership of the ABC and WIBC was approximately ten million people in 1992. That's almost 4% of the entire population of America, and it doesn't even count all those everyday bowlers who don't belong to a conference, but who bowl occasionally just for the fun of it.

HOW BOWLING IS DONE

THE BOWLING ALLEY

Bowling is done in a bowling "alley," or "lane," as it is sometimes called, which is 62 feet 10 inches long and about 41 inches wide. The area where the bowler stands is called the "approach area," and is 15 feet in length.

The foul line separates the approach area from the alley. Nine-inch-wide gutters run along both sides of the alley. At the other end of the alley, ten bowling pins stand, arranged in a triangular formation as shown on the right.

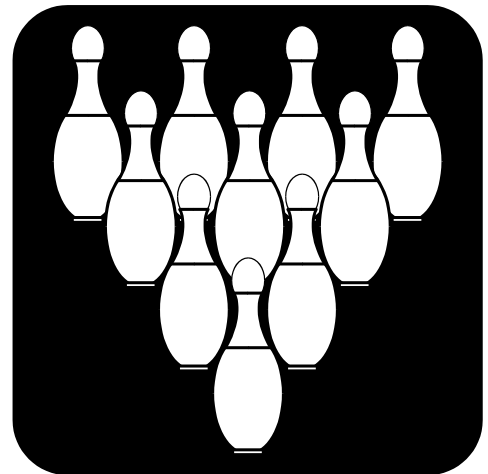

The object is to knock down as many pins as you can each time you send the ball down the alley. The more often you knock all of them down each time you bowl, the higher your score will be. Each pin that is knocked down counts as one point.

Each game is divided into ten "frames," during which each player has a chance to knock down the pins. If you knock down all the pins during each frame, you will score 30 points per frame and 300 points for the game.

For a novice bowler, a score of 120 or so is considered good. A score between 160 and 180 is good for a regular bowler, while professionals average more than 200 points in a single game.

In each frame, the bowler gets two chances unless the first try is a strike (knocking all the pins down at one time). The scores are all marked on a score sheet using symbols as follows:

X This stands for a **strike**, which means that all the pins have been knocked

down in one turn.

- / This stands for a **spare**, which means that all pins have been knocked down in two turns. A bowler is awarded 10 points plus a bonus of the score on the next roll. If a spare is made on the final frame, one extra roll is permitted.
- O The zero is used to show a **split** ball, which occurs when the headpin is down and the remaining pins have another pin down immediately ahead of or between them. Remember that a split leaves pins that are not close together standing and it is therefore harder to knock them down in one try.
- F This mark means a **foul**, which happens when a player goes beyond the foul line. A hand or arm, however, may extend over the foul line with no penalty. When a foul occurs, no score is recorded for that shot.

PLAYING TECHNIQUES

BASIC BOWLING MOVES

FOUR-STEP DELIVERY

The bowling pins may be approached in many different ways, but the most basic is called the “four-step delivery.” Here is a summary of each step:

STEP ONE: If the bowler is right-handed, he or she should make the following seven movements:

1. Bend forward
2. Move the right foot forward about 12 inches.
3. Hold the ball forward and to the right.
4. Allow the left hand to leave the ball.
5. Keep the right wrist firm.
6. Keep shoulders parallel to the target.



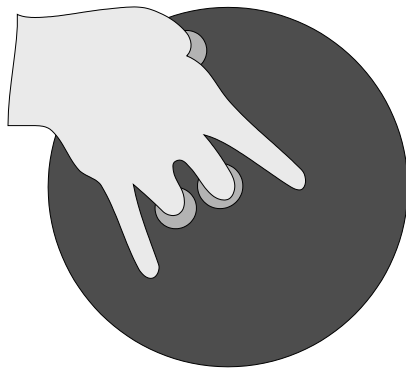

7. Focus the eyes on the target.

STEP TWO: This step focuses on the left foot and right arm. Keep the right arm as close as possible to the body as the ball is swung backwards.

STEP THREE: The ball now reaches the peak of the backswing (about shoulder height). Keep the movements smooth and deliberate and don't rush.

STEP FOUR: This step involves twelve movements:

1. Push forward off the right foot.
2. Slide on the front of the left foot.
3. Bend the left knee.
4. Bend at the waist and lean forward.
5. Let the ball swing forward under its own momentum.
6. Keep the right wrist and arm straight.
7. Keep the thumb positioned at "11 o'clock" ("1 o'clock" for left-handed persons).
8. The left knee continues to bend as the left foot slides to a stop.
9. The slide is completed a few inches from the foul line.
10. The left foot is pointed straight ahead.
11. The ball is released across the foul line.

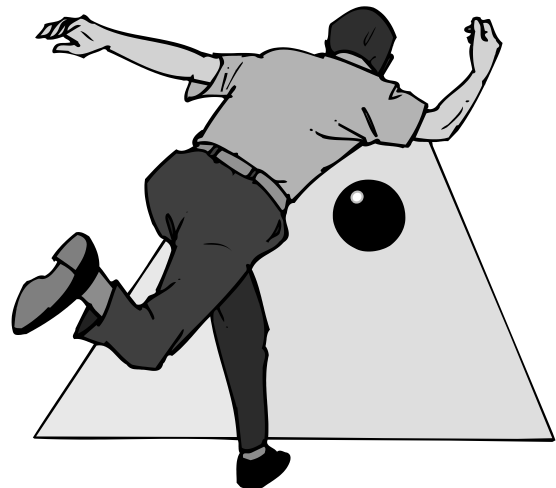

12. The left arm and right foot extend for balance.

FOLLOW-THROUGH

When the ball is released, the thumb comes out first, followed by the other fingers.

At this point, the arm is in a forward position and should continue to rise up to shoulder level. Some bowling instructors don't emphasize the follow-through, claiming instead that it occurs naturally if the ball is thrown correctly. Other instructors feel that follow-through is an important if neglected part of bowling. Try both to see which one works better for you.



FOUR BASIC SHOTS

The four basic shots indicate the way in which the ball rolls down the alley. These four shots are the:

straight ball

hook ball

curve ball

backup ball

The **straight shot** is exactly what its name implies except that it is rolled down the alley slightly off center in order to hit the first pin at an advantageous angle.

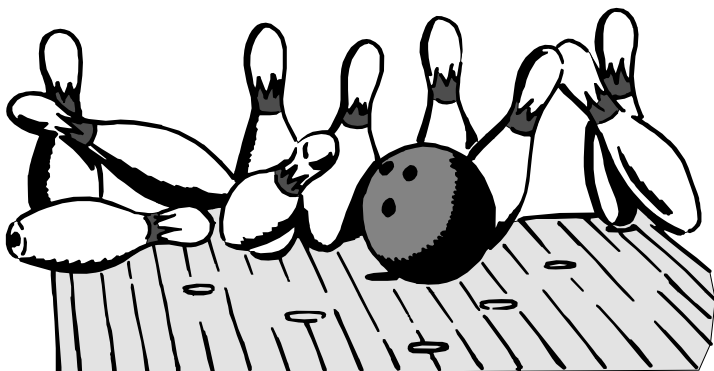

The **hook shot** consistently beats other shots in producing strikes. The hook, if thrown properly, will start a chain reaction among the pins. The hooking motion of the ball's trajectory results from the way in which the middle and ring fingers are released as the ball is thrown onto the alley.

The **curve ball** is difficult to control.

It is actually an exaggerated version of the hook shot, but because of the side path, there is more room for error in this shot.

The **backup shot** is seldom used. It works from left to right, the exact opposite of the other three shots. Most professional players advise against using this type of shot.

EQUIPMENT AND CLOTHING

The two essential pieces of equipment needed in bowling are a bowling ball and a pair of bowling shoes. Clothing can be any comfortable, loose-fitting sportswear that allows room for free movement.

Weight, span and pitch must all be considered in selecting a bowling ball. “Span” is the distance between the thumb hole and the finger holes. “Pitch” is the angle at which the finger holes are drilled. With regards to weight, the rule of thumb is to select the heaviest ball that can be handled with ease. Choosing a ball that is too heavy and becoming fatigued from using it defeats the purpose of the game.

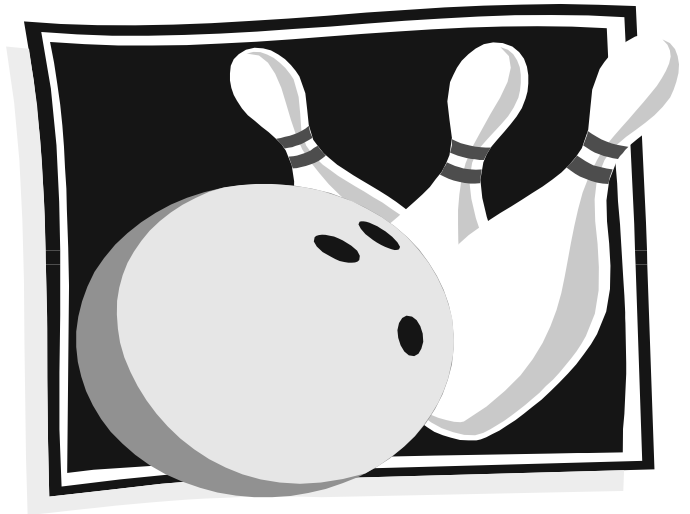

A good pro shop can help a beginning bowler decide where holes should be drilled in the ball to insure a comfortable fit.

The choice of bowling shoes depends upon which hand the bowler uses to roll the ball. For example, if the bowler is right-handed, the left shoe needs to allow sliding while the right shoe provides the necessary traction. The opposite is true for left-handed bowlers.

BOWLING NOTES AND NEWS

Bowling is one of the most popular pastimes in North America. Friends, families and other ordinary folks meet at local lanes to bowl a few frames. Kids and grownups alike enjoy the game. Because recreational bowling doesn't require long hours of conditioning for strength or endurance, everybody gets a chance to bowl, both young and old.

On the competitive circuit, it's a different story. Concentration, practice, and the development of natural skills all go into making a championship bowler. While everybody knows somebody who bowls, few people know the champions.

Bowling has its own professional circuit, just like other sports.



The PBA Tour currently has four major championship events: the USBC Masters (known as the ABC Masters prior to 2005), the BPAA U.S. Open, the PBA World Championship, and the PBA Tournament of Champions. In the 2005-2006 season, the PBA held twenty-one tournaments. Tommy Jones was named the 2006 Chris Schenkel PBA Player of the Year Award winner.

Jones of Simpsonville, S.C. won a Tour-high four titles for the second consecutive season, becoming the first bowler to win as many as eight titles over two seasons since Parker Bohn III in 1998 and '99. One of Jones' four titles was his first career Major, which came in the 63rd U.S. Open in February, 2006.

In his fifth season on Tour, Jones led all bowlers in earnings with \$301,700, the third-highest single-season total of all-time.

In, 2005, the PBA signed a historic three year sponsorship deal with Denny's, which made the American restaurant chain the PBA Tour's first title sponsor. The 2006-2007 season, begins at the end of September 2006 and runs through April 2007.



Keep current with the circuit of competition for this popular sport. It is exciting to watch professional bowlers roll up top scores on television. It is also interesting to keep track of how professional as well as college bowlers are doing at a variety of web sites:

<http://www.bowlingmuseum.com/>

<http://www.pba.com/>

STUDENT RESPONSE PACKET

BOWLING

NAME _____

DATE _____

WHAT TO DO

The following questions will help you to have a greater appreciation and understanding of bowling. Write your answers in the spaces below the questions. If there is not enough room, write on the backs of these sheets. Be neat, spell correctly, and write in complete sentences.

1. What types of physical benefits can be obtained from bowling?

2. What basic equipment is needed for bowling?

3. What factors are important in selecting a bowling ball?

4. Describe the stages in a four-step delivery.

5. What is meant by “follow-through” in bowling?

6. What are the four basic shots in bowling?

7. What is a split ball?

8. What constitutes a foul in bowling?

9. How many times does each player get to bowl in a typical game?

10. How many frames are there per game? How many possible points can a bowler make? What would be a good score for a beginning bowler?

Name: _____ Date: _____

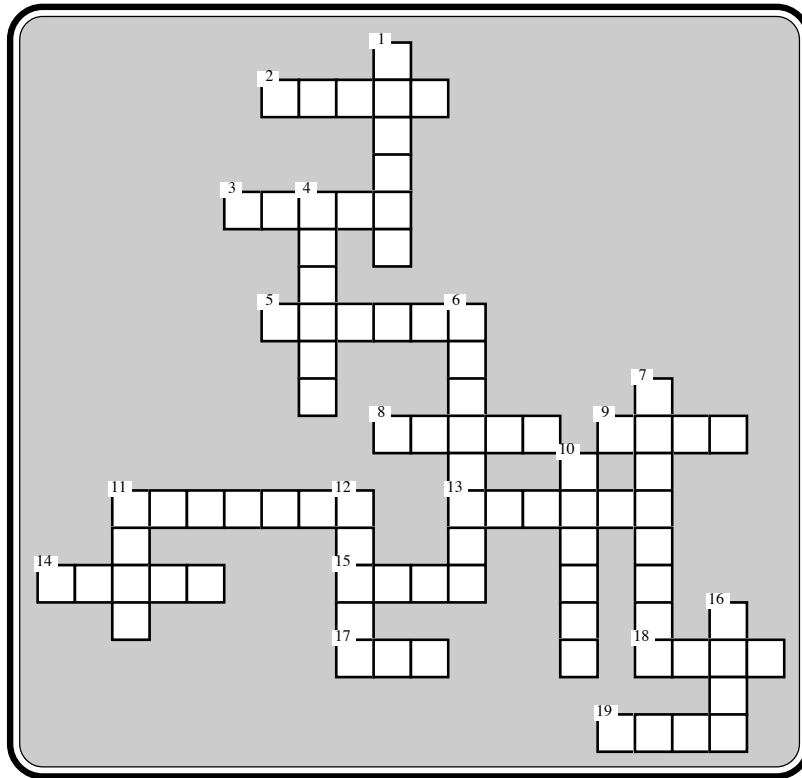

Across:

2. Where bowling is done
3. Angle which finger holes are drilled
5. Games are made of ten of these
8. The term used to describe knocking down all the pins in two turns
9. Distance on the ball between the thumb and finger holes
11. They come out last when the ball is released
13. When the ball rolls off of the alley it ends up here
14. What comes out first when the ball is released
15. This foot slides for right-handed bowlers
17. Number of pins in bowling
18. One of the types of shots in bowling
19. When a player goes over the line on the floor while bowling

Down:

1. How heavy a bowling ball is can be referred to as its _____
4. Points for knocking down all pins in one frame
6. This bowling shot does not curve
7. Area where bowler stands
10. The term used for knocking down all the pins in one turn
11. The number of basic shots in bowling
12. This term is used to describe the situation when the head pin is down and other pins are still up
16. One does this to the bowling ball to knock down the pins

Name: _____ Date: _____



Use the clues below to discover words in the above puzzle. Circle the words.

1. Angle at which the finger holes are drilled
2. When the ball goes off of the alley it ends up here
3. They come out last when the ball is released
4. This bowling shot does not curve
5. Points for knocking down all pins in one frame
6. Games are made of ten of these
7. This term is used to describe the situation when the head pin is down and other pins are still up
8. When the player goes beyond the foul line
9. Number of pins in bowling
10. What comes out first when the ball is released
11. One does this to the bowling ball to knock down the pins
12. Distance on the ball between the thumb and finger holes
13. Area where bowler stands
14. The number of basic shots in bowling
15. The term used to describe knocking down all the pins in two turns
16. The term used for knocking down all the pins in one turn
17. This foot slides for right-handed bowlers
18. Where bowling is done
19. The _____ of the bowling ball is how heavy it is
20. One of the types of shots in bowling

INSTRUCTIONS

This Learning Packet has two parts: (1) text to read and (2) questions to answer.

The text describes a particular sport or physical activity, and relates its history, rules, playing techniques, scoring, notes and news.

The Response Forms (questions and puzzles) check your understanding and appreciation of the sport or physical activity.

INTRODUCTION

Soccer is a fast-moving, action-packed sport. It is one of the most popular sports in the world today. Soccer, which is technically known as “association football,” was in fact the forerunner of modern football. Soccer was the only football-type game in the United States until American-style football became popular in the 1870s.



Today, soccer is included in the physical education programs of many schools. In addition, many elementary and high school students play it in organized after-school programs.

Soccer demands physically fit players since the game includes running as much as three or four miles per match. The player’s arms, legs, heart and lungs all get a good workout during the average soccer game.

HISTORY OF SOCCER

In 400 B. C., the Chinese played a version of soccer, using a ball stuffed with hair. The Romans also played a version of soccer called “harpastan.” Julius Caesar reportedly

used this game as training for his armies.

Soccer was also played in various forms in England for about four hundred years before it was finally accepted as a “respectable” game.

On May 21, 1904, the Federation Internationale de Football Association (F. I. F. A.) was founded for the purpose of formulating rules and regulations to govern the game of soccer. The F. I. F. A. today is responsible for all international games, as well as the World Cup Tournament, which is held every four years.

HOW SOCCER IS PLAYED

Points are made in soccer by kicking or butting the ball into the goal net. Players are not allowed to touch or carry the ball. The goalie can use his or her hands only in the penalty area. Soccer games are comprised of two 45-minute periods with one halftime rest break. When a soccer player commits a foul, the opposing team gets a free kick. Fouls are given for such things as kicking an opponent, jumping an opponent, striking or pushing an opponent and handling the ball with the hands.

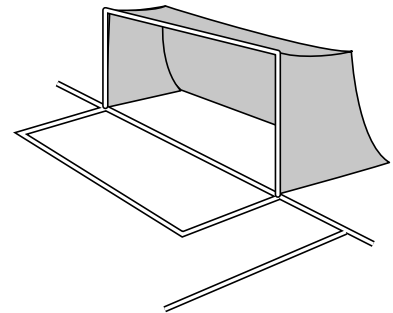

A soccer playing field is approximately 100 to 120 yards long and 55 to 75 yards wide. The goal net is 8 feet high and 24 feet wide.

A soccer team consists of eleven persons, all of whom work together to accomplish the team’s goals. Each of the eleven persons has a distinct job to do, and each of these jobs must be coordinated with the other ten players’ tasks.

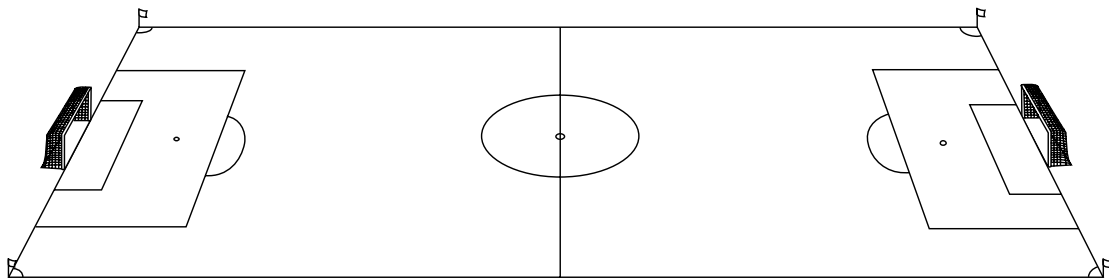

The eleven players include:

a goalkeeper

two backs

three midfielders

three strikers

two wingers



The **goalkeeper** stays close to the net, and is the only player who is allowed to use his or her hands.

The two **backs** are located near the goal area and protect the goalkeeper.

Midfielders (including right, center and left) are in constant motion during the game. These players run back and forth across the field throughout the game.

Strikers are considered the best all-around players. They must be adept at accurate passing as well as precision shooting with both feet.

The **wingers** (right and left outside forwards) are similar to basketball guards. These players must be able to control the ball in order to score the maximum number of points.

PLAYING TECHNIQUES

A unique aspect of the game of soccer is that the entire body, except for the arms and hands, is involved in the game. This is one major reason that soccer requires so much practice, especially for the beginning player. Even the simplest-looking moves are difficult to master. Experienced players practice constantly in order to maintain a high level of skill.

KICKING

Kicking is a critical skill in soccer. The soccer kick does not use a



regular kicking motion, which includes the toe. Instead, a soccer kick is really an instep kick which, properly performed, can send balls soaring up to 70 miles per hour. Professional observers say that properly-executed kicks separate the skilled players from the beginners.

OVERHEAD KICK

The overhead kick is used when a player wants to send the ball in the opposite direction from the one in which she/he is facing. An overhead kick can be used either on a ball in flight or on a bouncing ball. Timing and coordination are both extremely important in this move.



TRAPPING

“Trapping” the ball means that a player attempts to control a ball by stopping it or changing its direction. Trapping can be performed with any part of the body except the arms. Once the ball is trapped, it can be passed to another player or advanced on the field. A player may also attempt to make a goal with a trapped ball.



HEADING

This technique is used when the ball is too high to reach with any other body part. Incredible as it sounds, statistically a high percentage of goals have been head shots!

Timing is of critical importance in head shots. The player must meet the ball rather than allowing the ball to come down to meet him or her. The power in this shot results from the body being flexed backward as the ball is hit with the flat part of the forehead.

PASSING

Passing is the most critical move in soccer. It is an excellent way to advance the ball and requires highly coordinated teamwork.

While passing is somewhat similar to kicking, passing requires considerable practice to learn the exact amount of power needed to move the ball. The “push pass” (an inside-the-foot pass) is the most popular pass and can move balls up to 20 feet when properly executed.

DRIBBLING

Soccer dribbling is not the same move as basketball dribbling. However, both sports use this technique to move the ball along from one point to another.

In soccer, dribbling means touching or pushing the ball with the inside and outside portions of the foot. The object of dribbling in soccer is to move the ball approximately 10-12 inches.



EQUIPMENT AND CLOTHING

In soccer, attire that allows for freedom of movement and comfort are the main clothing requirements. Professional teams usually wear shorts, a jersey top and shin pads for lower leg protection.

Soccer shoes are perhaps the player's most important piece of equipment. They are manufactured to conform to specific regulations. Most professional soccer shoes have rubber studs or rippled rubber soles in order that they can be used on all types of surfaces.

SOCCER NOTES AND NEWS

In 1900, soccer became the first team sport to be added to the Olympic games. According to the 1996 Olympic Factbook (published in association with the Olympic Committee) soccer is the most popular sport in the world. At the 2004 Athens Summer Olympics, the medal winners were:

Men

GOLD: ARGENTINA
SILVER: PARAGUAY
BRONZE: ITALY

Women

GOLD: UNITED STATES
SILVER: BRAZIL
BRONZE: GERMANY



To participate in the World Cup is the dream of millions of young soccer players. The World Cup takes place every four years and is the most important soccer competition in the world.

In 2006, Italy won a penalty shootout 5-3 to lift the World Cup for the fourth time after French captain Zinedine Zidane was sensationally sent off near the end of the final that was tied 1-1 after extra time.

The French captain was shown the red card in the final match of his career for inexplicably headbutting Italian, Marco Materazzi.

Zidane had scored a seventh minute penalty to put France ahead in the final game with Materazzi equalizing 12 minutes later.

With the shock of Zidane's moment of madness still hanging over the Olympic stadium in Berlin, the greatest prize in world football went down to the lottery of spot kicks.



Italy kept their nerve the best with five immaculate penalties, the fifth and crucial strike from the boot of Fabio Grosso.

David Trezeguet's missed effort for France which hit the underside of the crossbar ultimately proved the difference, the only player from either side to miss.



Germany won the 2003 Women's World Cup by defeating Sweden 2-1. It was Nia Kuenzer that provided Germany with its first Women's World Cup championship. Eight minutes into overtime it was Kuenzer's goal that brought Germany the victory.

Germany has had superb women's teams for years. they've won five of the last six UEFA titles, including the last three, reached the 1991 World Cup semifinals, the final in 1995 and captured the bronze medal at the Sydney Olympics three years ago. In 1999, they appeared on the verge of upsetting the US, then watched two leads disappear.

The United States lost to the Germans in the 2003 Women's World cup semifinals 1-0.

1999 and 2003 Women's World Cup were both celebrated in the United States; in 2003 China was supposed to host it but it was moved because of SARS. As compensation, China retained its automatic qualification to the 2003 tournament as host nation, and received the 2007 tournament.



Marc Burch's deflected free kick gave Maryland a 1-0 win over New Mexico in the 2005 Men's NCAA Championship championship game, ending three years of frustration in which the Terrapins lost in the semifinals.

Maryland (19-4-2) broke through in the 30th minute when a foul on New Mexico's David Galdarama about 25 yards out gave the Terrapins a free kick. Burch fired a low, hard shot around the wall New Mexico set up. The ball nicked the foot of a Lobos defender, catching New Mexico goalkeeper Mike Graczyk leaning to his left and unable to get back to his right.

Maryland, won its first national soccer title since 1968, when it shared the title with Michigan State after the final ended tied 2-2 after two overtimes.

2005 was New Mexico's first appearance in a men's soccer final. The school's only national championship in a team sport was for skiing in 2004.



Christine Sinclair scored two goals and Portland beat UCLA 4-0 in the 2005 NCAA women's soccer national championship game. Angie Woznuk added a goal and an assist for the Pilots (24-0-2), who won their second title in three years.

For 2005, Portland became the only team other than North Carolina to finish an unbeaten season with a championship. The Tar Heels have won 10 of their 17 championships following undefeated seasons.

Sinclair, a member of the Canadian national team, set an NCAA single-season record with her first-half goals, giving her 39. Entering the game, Sinclair was tied SMU's Lisa Cole, who had 37 goals in 1987.

Find out more about what is happening in the sport of soccer by visiting these web sites:

<http://www.mlsnet.com/>

<http://www.collegesoccer.com/>

Name: _____ Date: _____

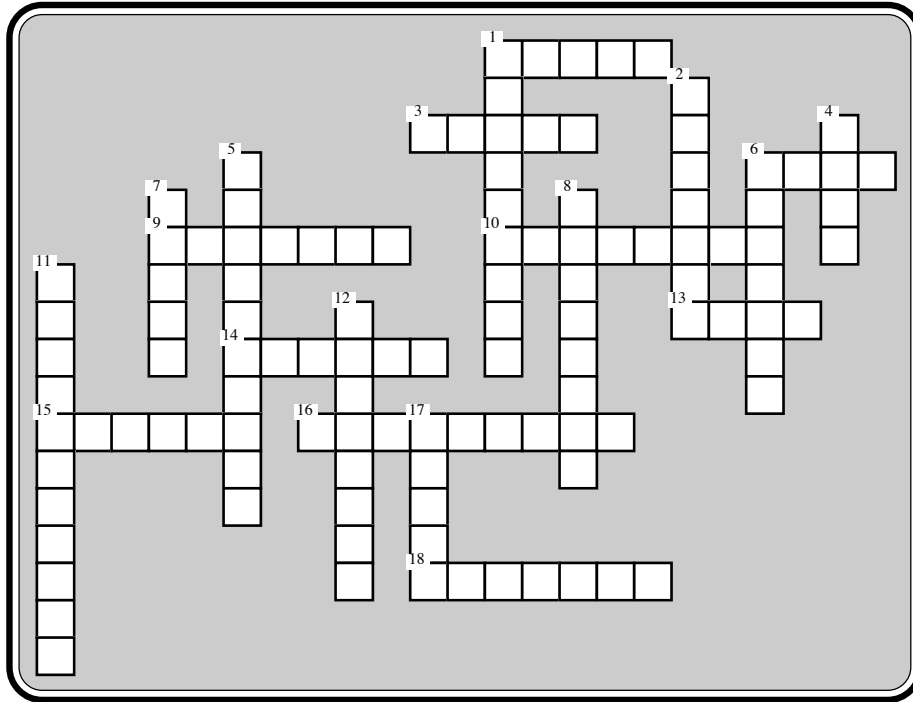

Across:

1. Soccer players should not use this part of the body
3. International soccer competition takes place at the _____ cup
6. Most popular type of pass in soccer
9. The player does this to make contact with a ball that is too high to reach with a foot
10. Some consider these to be the best all-around players
13. Pads for leg protection
14. The number of players on a soccer team
15. One should use this part of the body when kicking the ball
16. Moving the ball 10 - 12 inches per bounce and keeping control of it while moving
18. Possible miles-per-hour speed of a kicked soccer ball

Down:

1. Roman name for soccer
2. The players in this position are similar to guards in basketball
4. Acronym for the US Pro soccer organization
5. This is a player who can use his or her hands and stays near the net
6. Precision kicking - the most critical move in soccer
7. They often have cleats and some consider them to be the most important soccer equipment
8. Controlling the ball by stopping or changing its direction
11. They are in constant motion during the game
12. Type of kick that sends the ball in the opposite direction
17. These players help protect the goal-keeper

Name: _____ Date: _____

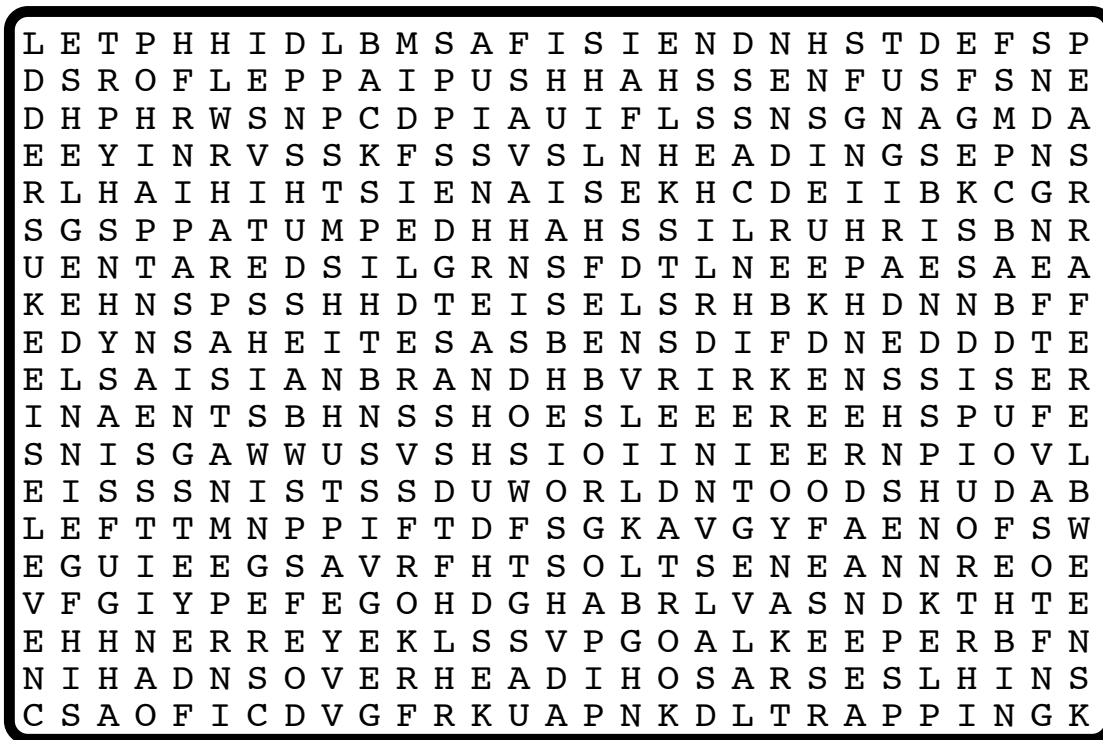

Use the clues below to discover words in the above puzzle. Circle the words.

1. Some consider these to be the best all-around players
2. Acronym for the US Pro soccer organization
3. Precision kicking - the most critical move in soccer
4. Roman name for soccer
5. They often have cleats and some consider them to be the most important soccer equipment
6. These players help protect the goalkeeper
7. International soccer competition takes place at the _____ cup
8. The player does this to make contact with a ball that is too high to reach with a foot
9. One should use this part of the body when kicking the ball
10. Possible miles-per-hour speed of a kicked soccer ball
11. Pads for leg protection
12. Type of kick that sends the ball in the opposite direction
13. Controlling the ball by stopping or changing its direction
14. The players in this position are similar to guards in basketball
15. Most popular type of pass in soccer
16. Moving the ball 10 - 12 inches per bounce and keeping control of it while moving
17. This player can use his or her hands and stays near the net
18. Soccer players should not use this part of the body
19. They are in constant motion during the game
20. The number of players on a soccer team

INSTRUCTIONS

This Learning Packet has two parts: (1) text to read and (2) questions to answer.

The text describes a particular sport or physical activity, and relates its history, rules, playing techniques, scoring, notes and news.

The Response Forms (questions and puzzles) check your understanding and appreciation of the sport or physical activity.

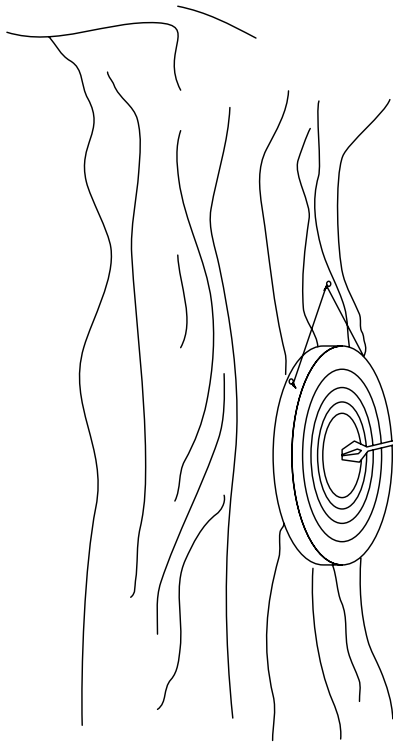

INTRODUCTION

With the possible exception of spear or javelin throwing, archery (using a bow to shoot an arrow) is probably the oldest sport in existence. It can be traced back to prehistoric times. Archery also played a major role in military history for thousands of years.

Today people participate in archery for the sheer enjoyment of target shooting and bowhunting. It is also a relatively inexpensive sport which can be practiced both indoors and outdoors.

Bowhunting for deer, peccary (wild pig) and other small game is gaining in popularity in the United States. Bow hunters often participate in competitions with full-sized three-dimensional targets made to resemble actual game.

For example, the annual “Mountain Man Classic” bowhunting competition in North Georgia involves running against the clock up and down 1-1/2 to 2 miles of steep wilderness terrain, spotting and shooting at deer and turkey targets that have been placed in obscure locations. This type of archery competition is extremely strenuous and requires months of endurance conditioning in addition to skills with a bow.

HISTORY OF ARCHERY

In prehistoric times, people used bows and arrows to hunt for food and for self-defense. During the Greek and Roman civilizations, armies used the skill of trained bowmen to win many battles.

Archery achieved new status as an American sport in 1828 when an association called “The United Bowmen of Philadelphia” was formed. This group is still in existence today.

The National Archery Association (NAA) was founded in 1879. It still sponsors annual national archery competitions.

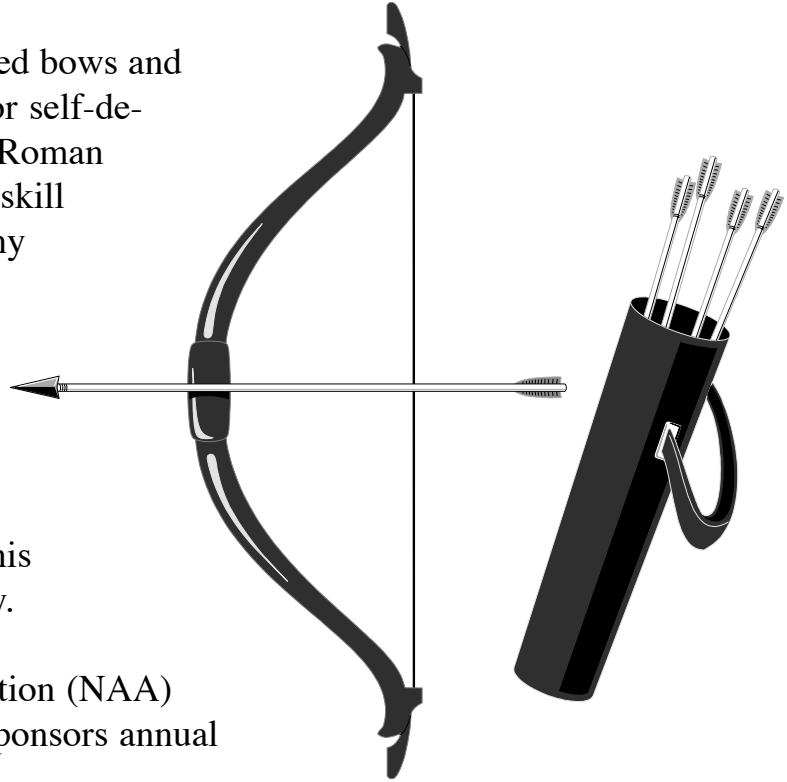

HOW ARCHERY IS DONE

The purpose of archery as a sport is to hit a target with an arrow. The highest score is made when a target designed with progressively smaller rings is hit in the center. This is the familiar “bullseye” target. Lesser scores are made as the arrow hits rings farther away from the center. Competition involves several archers, each trying to make the highest score possible in a specified number of tries.

SHOOTING TECHNIQUES

There is only one basic shooting technique in archery. An analysis of this technique helps us to identify ten basic steps as listed below. If all ten steps are done correctly, the shooting will appear to be graceful and almost effortless:

1. **Assuming the stance.** The archer should feel firmly placed but not stiff or tense. He or she should stand at right angles to the target with the eyes looking directly at the target.
2. **Positioning the bow arm and grip.** The bow is not really “gripped,” but is sup-

ported at arm's length from the body. The index finger or second finger is wrapped around the part of the bow that is facing the target, while the thumb is wrapped around the part of the bow that faces the archer. The shoulders are not "hunched," but are kept down and pulled to the back. The arm holding the bow is held as steady as possible without the muscles being tensed.

3. **Nocking.** The fletched or vaned end of the arrow has a small notch that fits over the bowstring. Slipping this notch over the bowstring is called "nocking."



4. **Drawing.** Drawing or pulling back on the bow string utilizes both arms and the upper body muscles. The bow arm is raised toward the target as the string arm pulls backwards. The upper arm, shoulder and upper back muscles should not be too tense, or the draw will be executed improperly. During this step, many archers find that it helps to take a deep breath and hold it.

5. **Anchoring.** It is critical that the string be pulled back to a proper anchor point. This is the point at which the bowstring arm has reached full flexion or bending at the elbow. The position varies according to the particular individual's skeletal and muscular lever system. As little as 1/8 inch in anchoring can affect shooting accuracy.

6. **Relaxing.** Archers need to take time to assure that only the muscles involved in supporting the bow and drawing the bowstring are tense. Overall performance improves when archers pay attention to this point.
7. **Aiming.** The sight-shooting method is a popular way of shooting at targets. A mechanical device is attached to the bow and can be both horizontally and vertically adjusted. The "sight" is fastened to the back of the bow slightly above the arrow rest. The archer should close the left eye or right eye (depending on whether the archer is right- or left-handed) and look at the "sight" pin. Then he/she should align it with the center (gold circle) of the target, also allowing for distance and wind (if any).
8. **Concentrating.** As with all sports, the ability to concentrate in archery often makes the difference between excellence and average performance. The archer should put everything else out of his/her mind and concentrate on the target.

9. **Releasing.** Smoothly release the string, holding the string fingers steady and relaxed without any snap or jerk to the hand. The arrow is now sent on its way.
10. **Follow-through.** Hold your stance for a few seconds after release.

EQUIPMENT AND CLOTHING

A first and major step in learning archery is identifying and understanding the equipment. A potential bowman will choose either a straight bow or a recurved bow (a bow in which the tips curve back to form an arc). The length of the bow depends on the individual needs of the purchaser, including his/her age, weight and height. Some hunting bows have complex compound curves, with equally complex systems of pulleys and bowstrings.

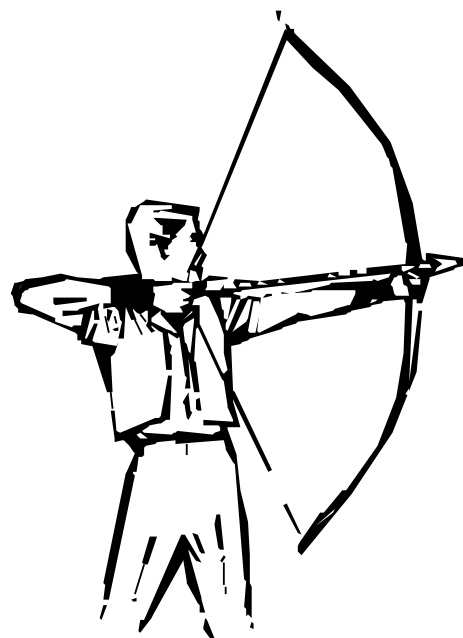

Bows range in length from 48 to 70 inches. Longer bows are used for target shooting and shorter bows for hunting. Most hunting bows weigh more than target bows, which usually range in weight from 10 to 50 pounds.

It is always best to buy a bow that is light enough to be handled comfortably. The “weight” of the bow does not refer to how much it would weigh if put on a set of scales. Instead, “weight” in archery refers to the amount of weight in pounds you would have to attach to the bowstring to bend a stationary bow a specific amount. This is often called the “draw weight.” Thus a 70-pound bow does not weigh 70 pounds. Instead, it requires 70 pounds of pulling force to bend the bow a certain amount.

Bowstrings are made of synthetic materials such as Nylon or Dacron. Archers often wax their bowstrings as protection against the elements.

Arrows are carried in an arrow holder called a “quiver,” or, in the case of hunting bows, are often attached to a rack on the bow itself. The arrow is composed as follows:

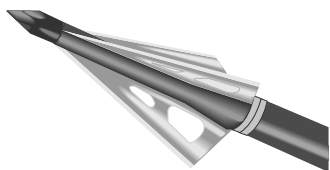

A point or “pile,” which varies from a simple sharp point to broadhead, quintuple-sectioned steeple-shaped heads.

A shaft and a “shaftment,” or rear of the arrow.

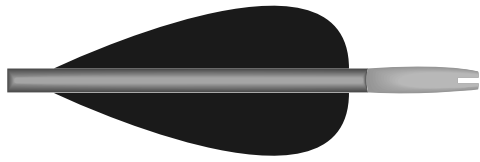

A “nock” or notch at the end of the arrow that fits over the bowstring.

Feathers, vanes or “fletches” at the nock end of the arrow, which help the arrow to fly in a straight line toward a target.

Some archers use a leather arm guard worn on the inside forearm of the hand that supports the bow. A leather tab or a shooting glove is often worn to protect the fingers that draw back the bowstring.

Archers should always wear comfortable, uncluttered, form-fitting clothes. Jewelry, large buttons, scarves and big pockets will only get in the way of the bow and arrow.

SAFETY TIPS

Although it involves the use of one of the oldest types of weapons, archery is not necessarily a dangerous sport. However, as with any physical activity, it is up to the individual to keep the sport as safe as possible by observing certain rules, especially the following four:

Novice (beginning) archers should always be supervised. Don’t try to get started in archery without prior instruction or supervision.

An arrow ready to be released should be pointed only at the target, never at persons, animals or objects.

Arrows should not be shot straight up into the air. When that happens, they usually come straight back down. This can be very dangerous!

Never take chances in archery. It’s better to be safe than sorry.

NOTES AND NEWS

In addition to being a form of recreation, archery is an Olympic sport. Olympic archery competition has strict equipment rules. For example, Olympic bows are recurved, and can

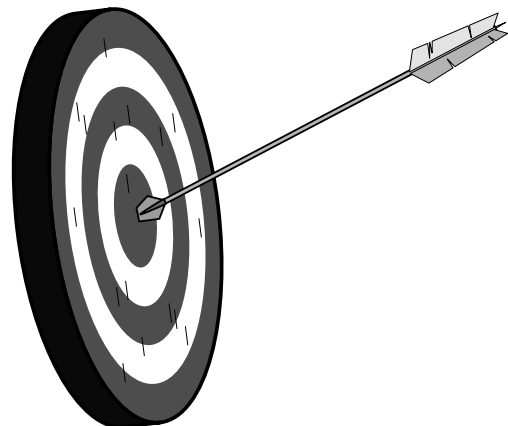

propel arrows up to 150 miles per hour. The draw weight averages 50 pounds for men and 34 pounds for women. Most arrows are made of either aluminum or carbon graphite.



20th WORLD FIELD ARCHERY CHAMPIONSHIPS: Gothenburg, Spain, 2006

<u>Event</u>	<u>Winners</u>	<u>Country</u>
Women's Compound Bow	Silke Hoettecke	Germany
Men's Compound Bow	M. Lundin	Sweden
Women's Recursive Bow	Dolores Cekada	Slovenia
Men's Recursive Bow	Michele Fragilli	Italy

Gold Medalists in the 2004 Olympic archery competition in Athens were as follows:

Men's Singles	Marco Galiazzo, Italy
Men's Archery Team	South Korea
Women's Singles	Park Sung-hyun, South Korea
Women's Archery Team	South Korea

Keep current with this exciting sport. Although it is an ancient sport, archery continues to grow in popularity. Visit these websites to learn more:

<http://usarchery.myicontrol.com/>
<http://www.archerynetwork.com/>
<http://fw.ky.gov/archflyer.asp>

Name: _____ Date: _____

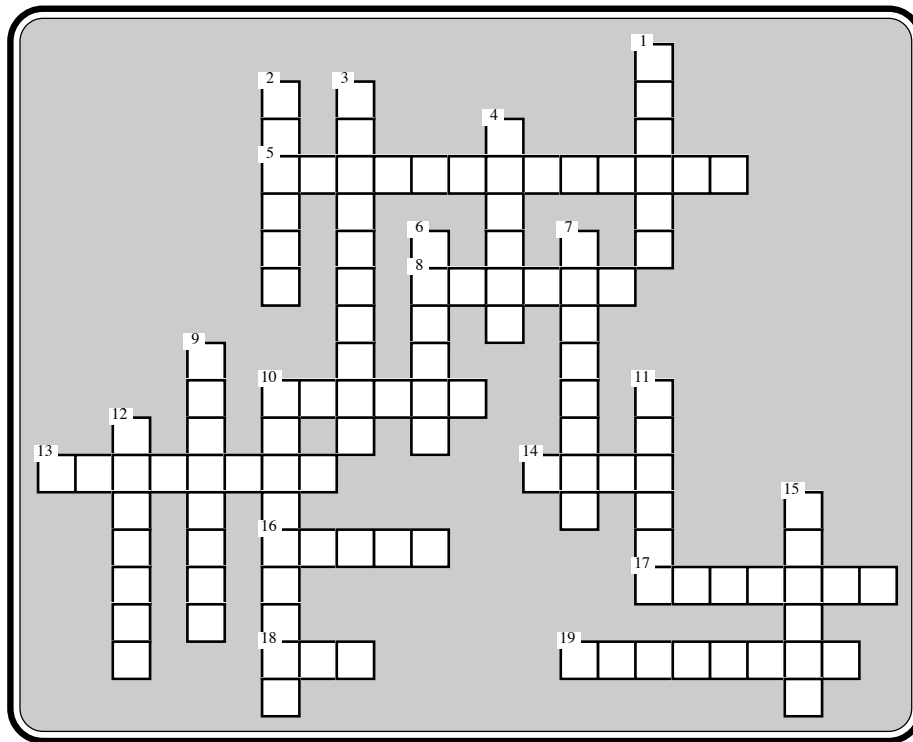
**Across:**

5. Putting everything out of your mind but the target
8. The point at which the bowstring is pulled back fully
10. When drawing, the bow arm is _____ toward the target
13. This is how one should release the bowstring
14. Another name for an arrow point
16. This is shot by the bow
17. This word describes pulling back on the bowstring
18. Acronym for the archery association founded in 1828
19. Type of bow that is often used for hunting

Down:

1. A sight-shooting method
2. The thumb supporting the bow faces this
3. Arrangement for rings in an archery target
4. Standing at right angles to the target
6. The fingers supporting the bow face this
7. The annual _____ man competition is for bowhunters
9. The end of the arrow with the nock
10. Letting go of the bowstring
11. When anchoring, the arm is fully _____ at the elbow
12. Placing the arrow against the bowstring
15. Arrow holder

Name: _____ Date: _____

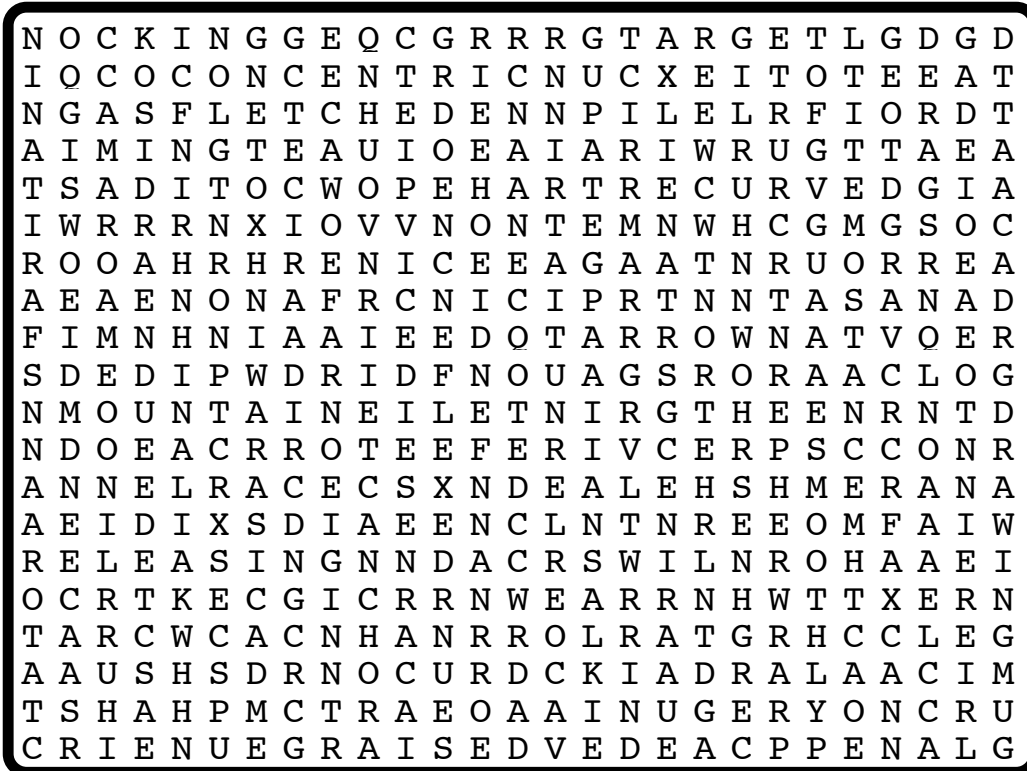

Use the clues below to discover words in the above puzzle. Circle the words.

1. The point at which the bowstring is pulled back fully
2. This is how one should release the bowstring
3. The fingers supporting the bow face this
4. Standing at right angles to the target
5. Putting everything out of your mind but the target
6. The annual _____ man competition is for bowhunters
7. A sight-shooting method
8. Letting go of the bowstring
9. Acronym for the archery association founded in 1828
10. The end of the arrow with the nock
11. Placing the arrow against the bowstring
12. The thumb supporting the bow faces this
13. When anchoring, the arm is fully _____ at the elbow
14. Type of bow that is often used for hunting
15. Another name for an arrow point
16. When drawing, the bow arm is _____ toward the target
17. Arrangement for rings in an archery target
18. This is shot by the bow
19. This word describes pulling back on the bowstring
20. Arrow holder

INSTRUCTIONS

This Learning Packet has two parts: (1) text to read and (2) questions to answer.

The text describes a particular sport or physical activity, and relates its history, rules, playing techniques, scoring, notes and news.

The Response Forms (questions and puzzles) check your understanding and appreciation of the sport or physical activity.

INTRODUCTION

Wrestling is a “basic sport” in the sense that it finally comes down to the strength and skill of one person pitted against that of another. Practically every muscle in the body is used in wrestling. Moreover, training must produce strength, speed and endurance. A participant must be in excellent physical condition.

The two most popular styles of wrestling practiced in the United States are the Greco-Roman style and Freestyle.

In the **Freestyle** form, a wrestler can use his/her hands, arms, legs and feet to overcome an opponent. This style also allows for great freedom of movement and allows both tripping and tackling.

The **Greco-Roman** style forbids the use of the legs and relies instead on arm and upper-body strength. The Olympic Games currently include both styles of competitive wrestling.



HOW WRESTLING MATCHES ARE PERFORMED

A wrestling match takes place on a mat with a circle in the center, about 28 feet in diameter. At the Olympic level, a match is composed of three 3-minute periods. On the

high school level, a match is comprised of three two-minute periods. College matches are made up of a two-minute period followed by two three-minute periods.

Typically, wrestlers are grouped by weight. High school wrestling has 13 weight classes, starting at 103 pounds and going up to 275 pounds. College wrestling has 10 weight classes, starting at 118 pounds. The advanced wrestler may enter any of eight different weight classes in international competition.



In the first period, wrestlers try to force their opponents onto the mat in a “takedown.” The period begins with the wrestlers facing each other in a standing position. A toss of the coin determines starting positions for the second and third periods. In the second and third periods, wrestlers can start while standing or can begin in the referee’s position, which means that the wrestler on the bottom has his or her hands and knees on the mat.

These are the three different ways matches are won:

By pinning the opponent’s shoulders flat to the mat.

By a technical fall or a 15-point lead.

By winning the most points.

A match can end in any period. Even if a wrestler has fewer points than his or her opponent, he or she can still win if he/she pins the other wrestler to the mat.

WRESTLING TECHNIQUES

When one wrestler gains control over another wrestler by bringing him/her down, a takedown has occurred and two points are scored. If a wrestler frees himself or herself from the opponent’s control and then gains control of the opponent, a reversal has taken place—worth two points.

Another two-point move is called a “predicament,” and occurs when one wrestler controls the other. The referee then decides that a near fall may occur. A near fall is worth

two, sometimes three, points. In this move, a wrestler must pin one of his or her opponent's shoulders to the mat and hold the other shoulder near the mat at an angle less than 45 degrees.

Two points are awarded if the hold is maintained less than five seconds. The move becomes a three-point award when the maneuver is held close to the mat for more than five seconds. If a wrestler can pin both of his/her opponent's shoulders to the mat for five seconds, six points are awarded.

TAKEDOWNS, ESCAPES AND REVERSALS

The takedown, escape and reversal are important basic moves that beginners should master.

A **double-leg takedown**, one of the basic takedown maneuvers, begins when you put your foot between your opponent's feet. Then take your lead knee to the mat and lock both arms around the opponent's thigh. The opponent is taken off the mat and over your shoulders, then dropped back down on the mat.

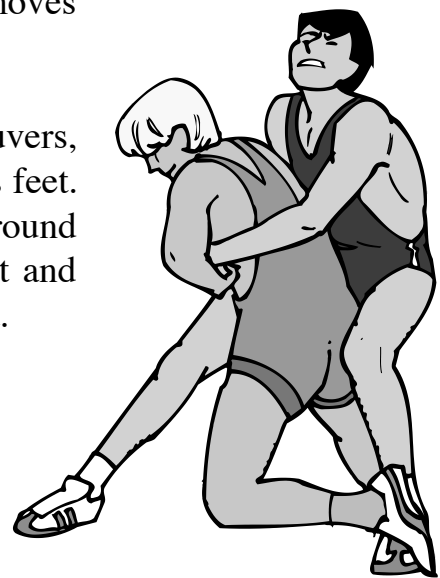

The **high-crotch takedown** depends on quick reactions and strength. If an opponent grabs your neck, a counter-move is to take hold of the opponent's elbow. The elbow is pushed toward the opponent's body, then pulled out as you drop to your knee and place a free arm between your opponent's legs. Then dropped your opponent over your shoulder to you gain control of him or her.

Two other takedowns that rely particularly on strength are the **bearhug** and the **headlock**. In the bearhug, you grab the torso of the opponent, throwing the opponent to the side or pushing him/her backward so that the opponent falls.

The headlock requires you to wrap an arm around the opponent's head and force the opponent down or throw him/her to the side.

The **inside-leg stand-up** is a basic escape maneuver. This move allows the wrestler on the bottom to get free and try to gain control.

The **short-sit-out** is an escape move that allows the wrestler on the bottom to get his/her legs into a sitting position. Escapes can sometimes be difficult to accomplish, especially

if the wrestlers are evenly matched in size/strength.

The **side roll and switch** are two reversals that are especially good for beginning wrestlers to master. The reversals start from the bottom position and depend on strength and quick reactions in order for the bottom wrestler to get on top.



PSYCHOLOGICAL FACTORS

Psychological factors are all-important in wrestling. All other things being equal, a wrestler has a better chance of success if he/she has a strong will to win. Confidence in one's ability is as important in wrestling as is the ability itself. So is concentration and the ability to focus exclusively on one's performance and one's opponent. Remember, however, that confidence is not some magic ingredient that will help you win matches. Confidence is gained by hard work and the development of wrestling skills.

Wrestling also demands year-round practice. In this respect it is not a sport for everyone. Certainly, it's not a "weekend" sport like golf. A young wrestler must work on building strength through resistance and aerobic training, proper nutrition and rest.

EQUIPMENT AND CLOTHING

Wrestling requires only a minimum amount of equipment. Wrestlers traditionally wear an outfit called a singlet—a one-piece garment with shorts and a sleeveless top. Shoes are lightweight, ankle-high and without heels. In recent years, protective headgear covering the ears has become a standard requirement.

WRESTLING NOTES AND NEWS

Wrestling exists in two versions in North American popular culture: as a legitimate sport and as a form of entertainment. As a sport, wrestling does not have the popularity of football or basketball. But as a form of entertainment, as witnessed in associations such as the World Wrestling Federation, it fills arenas, magazines and TV screens.

Wrestling is also an Olympic sport, where Freestyle and Greco-Roman are the only permissible styles. Both Greco-Roman and Freestyle wrestling are divided into 10 weight classes, ranging from 48 kg. to 130 kg.

Recent Olympic rule changes have increased the spectator enjoyment of wrestling. In 1989, matches became one-period, 5-minutes contests. This change decreased the importance of endurance and increased the importance of speed and skill.

The greatest American heavyweight freestyle Olympic wrestler is Bruce Baumgartner, who has been in Olympic competition in 1984, 1988, 1992 and 1996. He holds four gold medals and one silver medal.

You can get a feel for the international flavor of wrestling with this abbreviated listing of freestyle medalists from the Athens Olympics in 2004:



<u>Wrestler</u>	<u>Country</u>	<u>Medal</u>
<i>55kg:</i>		
Mavlet Batirov	Russia	Gold Medal
Stephen Abas	USA	Silver Medal
Chikara Tanabe	Japan	Bronze Medal
=====		
<i>66kg</i>		
Elbrus Tedeyev	Ukraine	Gold Medal
Jamill Kelly	USA	Silver Medal
Makhach Murtazaliev	Russia	Bronze Medal
=====		
<i>84kg</i>		
Cael Sanderson	USA	Gold Medal
Moon Eui-jae	South Korea	Silver Medal
Sazhid Sazhidov	Russia	Bronze Medal
=====		
<i>96kg</i>		
Khadjimourat Gatsalov	Russia	Gold Medal
Magomed Ibragimov	Uzbekistan	Silver Medal
Alireza Heidari	Iran	Bronze Medal
=====		
<i>120kg</i>		
Arthur Taymazov	Uzbekistan	Gold Medal
Alireza Rezaei	Iran	Silver Medal
Aydin Polatci	Turkey	Bronze Medal

NCAA Tournament



In 2006 Oklahoma State clinched its 34nd NCAA national title as the Cowboys won the team trophy at the Division I Wrestling Championships. This was the Cowboys fourth straight title. Oklahoma State won the tournament with 122.5 team points followed by Minnesota with 84 points.

In March, 2006, Oklahoma State also won its eighth Big 12 Championship at the Hilton Coliseum in Ames, Iowa. The Cowboys earned 80 points, followed by Oklahoma with 52.5 points, Nebraska with 52, Iowa State with 47.5 and Missouri with 42.

High Schooler Makes News

Girls are finding their way onto the wrestling mat. Some high schools are permitting girls to compete. In the photo to the right, Anchorage Skyview's Michaela Hutchison, top, works against Colony's Aaron Boss in the championship round of the 103-pound weight class at the state wrestling championships in Anchorage, Alaska, February. 4, 2006. Hutchison won the match to become the first female in the nation to win a prep state wrestling title against boys

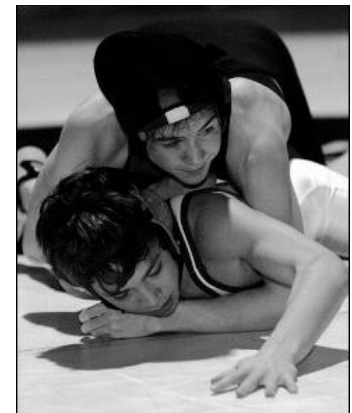

Wrestling is an exciting sport both for participants and spectators. You'll find top-notch competition on both high school and college levels. Make it a point to see a wrestling meet this year.

Visit these web sites to keep up to date on what is happening in the world of wrestling:

<http://www.ncwa.net/>

<http://www.ncwa.net/>

5. What is “a takedown” in wrestling?

6. Name three different ways to win a match.

7. What is “a predicament”?

8. What is “a reversal?”

9. Why are psychological factors so important in wrestling?

10. What two types of takedowns rely especially on strength?

Name: _____ Date: _____

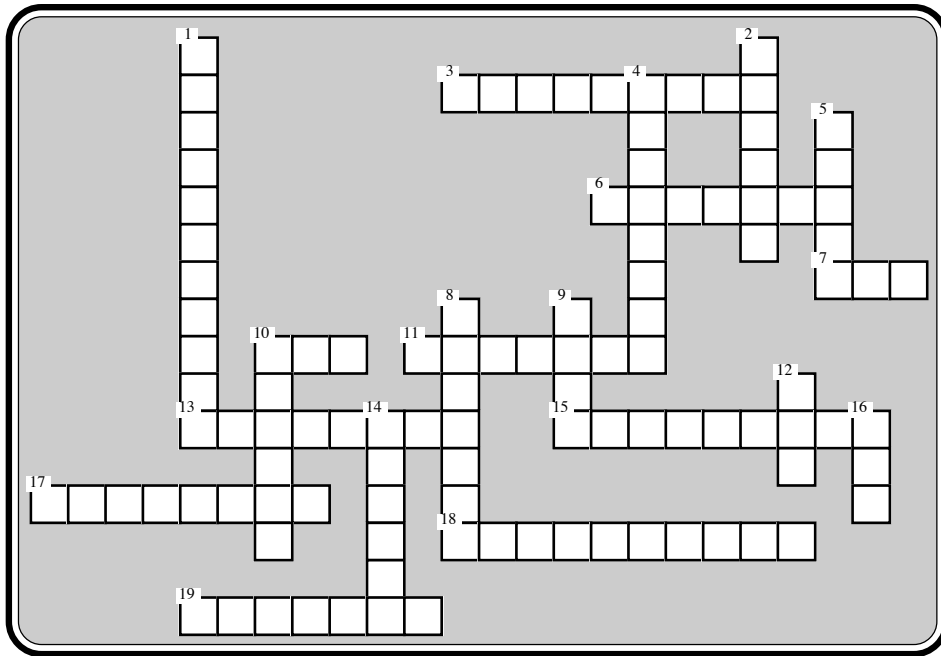

Across:

3. One form of wrestling
6. Grabbing an opponent's torso
7. Points awarded if hold is maintained less than five seconds
10. Points awarded if hold is maintained over five seconds
11. Points lead needed to win a match
13. The number of weight classes in high school wrestling
15. One way to win a match is to pin these to the mat
17. Grabbing an opponent's head
18. A form of wrestling
19. One-piece garment worn by wrestlers

Down:

1. What happens when one wrestler controls the other
2. This is how wrestlers are grouped
4. Maneuver to get opponent on the mat
5. The number of weight classes in international wrestling
8. Takes precedence over points
9. These are not used in Greco-Roman wrestling
10. A reversal maneuver
12. The number of weight classes in college wrestling
14. Purpose of an inside-leg standup
16. A short _____ out is done to escape

Name: _____

Date: _____



Use the clues below to discover words in the above puzzle. Circle the words.

1. One-piece garment worn by wrestlers
2. A short _____ out is done to escape
3. Takes precedence over points
4. One way to win a match is to pin these to the mat
5. Points lead needed to win a match
6. A reversal maneuver
7. Points awarded if hold is maintained over five seconds
8. The number of weight classes in college wrestling
9. The number of weight classes in high school wrestling
10. The number of weight classes in international wrestling
11. Purpose of an inside-leg standup
12. Points awarded if hold is maintained less than five seconds
13. What happens when one wrestler controls the other
14. Grabbing an opponent's torso
15. Grabbing an opponent's head
16. A form of wrestling
17. One form of wrestling
18. Maneuver to get opponent on the mat
19. These are not used in Greco-Roman wrestling
20. This is how wrestlers are grouped

INSTRUCTIONS

This Learning Packet has two parts: (1) text to read and (2) questions to answer.

The text describes a particular sport or physical activity, and relates its history, rules, playing techniques, scoring, notes and news.

The Response Forms (questions and puzzles) check your understanding and appreciation of the sport or physical activity.

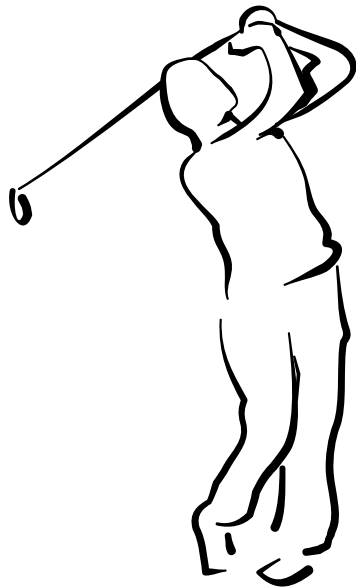

INTRODUCTION

Golf is the most popular and fastest-growing sport in many countries today. People of all ages can (and do) play golf, at many different levels of skill.

Why is golf so popular? It's relaxing, it's good exercise and it's played in pleasant surroundings. It presents challenges, yet isn't too taxing to be played at an amateur level.

Golf is also a great spectator sport. Thousands of viewers watch the sport on television, while thousands more follow their favorite golf pro to tournaments.

HISTORY OF GOLF

According to legend, a shepherd in Scotland hit a stone with a stick and watched the stone soar in the air. Thus the game of golf was born!

Golf flourished first in Scotland and later in England. The first golf balls used in England around the fifteenth century were called "feathery" because they were made of leather and stuffed with feathers.

The game of golf grew in popularity, especially among the wealthy because it was seen as a game played and controlled by the upper classes. Although many people still con-

sider golf “a rich man’s game,” public courses in contemporary America are open to the population at large.

Golf first became popular in America around 1895, when the first U. S. Open Tournament was held. The first 18-hole golf course opened in Wheaton, Illinois in 1893.

HOW GOLF IS PLAYED

Golf is played on a golf course. Full-sized courses have 18 holes, while smaller courses have only 9 holes. Golf balls are placed on small wooden or plastic supports called “tees,” which are pressed into the ground on a “teeing ground.” Golf clubs are used to hit the balls off the tees in the direction of the next hole, which is on what is called a “green” or “putting green.” The area between the tee and the green is called the “fairway.” Trees, lakes, streams, sand, and other obstructions may be on either side of the fairway. Sometimes, fairways are shaped like arms that are bent at the elbows.

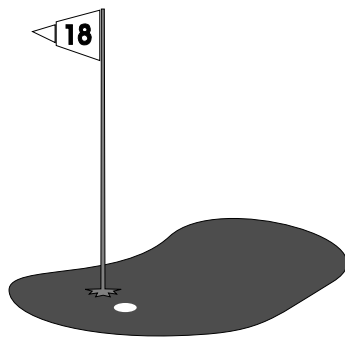
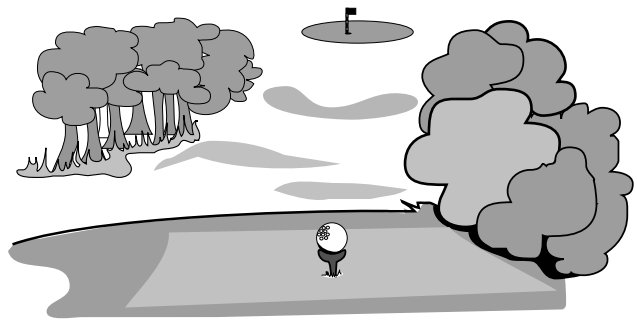

The object of the game is to hit the golf ball off the tee, up the fairway, to the putting green, and into the hole with the fewest number of strokes possible. Each hole has a designated number of strokes. This designated number of strokes is called “par,” from which we get the popular expression, “par for the course.” Thus, a good player can move the ball from the tee to the hole on a “par 4” hole in four strokes. Par can vary from three to five strokes, depending on the difficulty of the course and the distance of the hole from the tee.

An excellent player may put the ball in the hole with fewer or greater strokes than are assigned as par for a particular hole. When this is done, there is a name for it:

- | | |
|---------------|---|
| BIRDIE | Hitting the ball into the hole with one stroke under par. |
| BOGIE | Hitting the ball into the hole with one stroke more than par. |
| EAGLE | Hitting the ball into the hole with two strokes under par. An |

Eagle is possible on any hole above par 3.

ACE

Hitting the ball into the hole with one stroke. An “ace” is also called a “hole in one.”

According to golfing rules, once the ball is placed on a tee, it cannot be touched by anything other than a golf club until it is taken out of the hole. Most golfers strive to keep the ball on the fairway, the area between the teeing ground and putting green. If a ball is hit badly, it may end up “in the rough,” or the area near the fairway with bushes, trees and tall grass. Balls which are hit inaccurately also may end up in bunkers or sand traps.

GOLF ETIQUETTE

All sports require that the participant practice sportsmanlike behavior. Part of the goal of sports is learning how to be both a good winner and a good loser. Golf is no exception. Always observe the following six rules of golf etiquette:

1. Don't talk or move around when a player is about to hit the ball. All players should keep their distance from the golfer who is about to hit the ball. She or he should not be distracted by talking or movements by other players.
2. Replace any damage done to the course. If your golf club digs up a chunk of grass (a “divot,” in golfing terminology) on a shot, put the grass back where it came from. Also, rake a sand trap smooth after stepping out of it.
3. When a group of players is particularly slow, the group behind should be allowed to move ahead.
4. Technically, each group should be allowed to finish the hole before the next group starts. No one can tee off when another group is finishing up on the putting green. On holes of great distance, a group may tee off when the party in front of them is still on the fairway, but at a safe distance.
5. Help keep the putting green in immaculate condition. Keep carts and golf



cars away from the greens.

6. Learn the proper way to warn other players about an approaching ball. If a player hits a ball too hard, inaccurately or carelessly and it heads for another player, the golfer who hit the ball should yell out “Fore!” to warn others.

PLAYING TECHNIQUES

THE GRIP

The grip is an important element in golf since the hands are the only parts of the body that touch a golf club. There are three types of grips in golf, as follows:

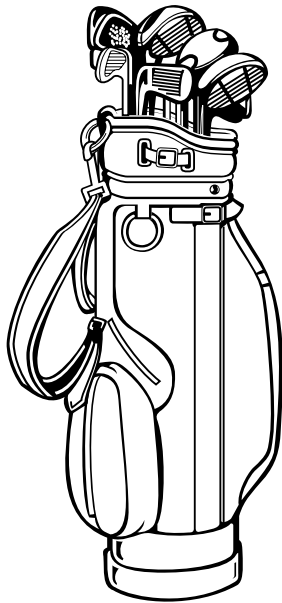

The interlocking grip. This type of grip is good for persons with shorter fingers. The little finger of the right hand locks between the index finger and the middle finger of the left hand. This is an extremely stable grip, and keeps the hands and fingers in the same position throughout the swing.

The overlapping grip. In this grip, the little finger of the right hand overlaps the index finger and middle finger of the left hand (the opposite if you are left-handed). This is a stable grip, but not as stable as the interlocking grip.

The baseball grip. In this type of grip, all ten fingers are on the club (as one would do in holding a baseball bat), with no interlocking or overlapping. This grip is not as stable as either of the other two grips.

No one type of grip is absolutely superior to the others. Different people have different skeletal lever systems, and different muscular development. Some people like the interlocking grip because of its stability. Others find it too confining and difficult to use. The choice of grip depends on which one best suits the individual golfer.

THE GOLF SWING

In order to hit a golf ball accurately from a specific distance, a player must know the fundamentals of the golf swing. The correct way to swing can be broken down into steps, as follows. However, note that the swing, when performed properly, is one con-

tinuous smooth motion:

1. Stand before the ball with the face (flat area) of the golf club head positioned next to the ball. This is called “addressing the ball”. If you are right-handed, your left side will be turned toward the green. The opposite is true if you are left-handed. Keep your eye on the ball as you start your backward swing.
2. Swing the club in an arc backward away from the ball. When the club is at about waist height, your wrists will remain stable as you grip the club. The shoulder facing the green will come up under the chin and the hips will begin to rotate away from the green. Keep your eye on the ball.
3. When the golf club is brought back as far as it can go in the backswing, your shoulders should be turned about 90 degrees from the direction your toes are pointing. Your hips should be turned about 45 degrees. Don’t take your eye off the ball.
4. Start the downward motion of the club with a rotation of your hips toward the direction of the green. Keep your eye on the ball.
5. Follow the hip motion with the arms coming down with the wrists still stable. Do NOT lead the motion with the arms; lead with the hips. Keep your eye on the ball.
6. As the arms straighten, the club face hits the ball. Follow the ball with your eyes.
7. The swing does not stop at this point. The club continues to follow its path in the direction of the green as you finish off the swing. This is called the “follow-through.”
8. Make every swing a full swing.

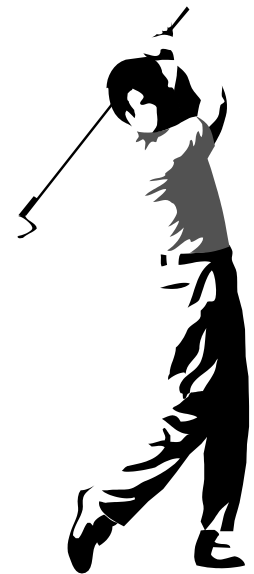

If a golf swing is properly done, it should look and feel smooth, effortless, and powerful, accomplished in a single smooth motion in the backswing, then a single smooth motion

through the arc of the forward swing and into the follow-through.

Strength doesn't necessarily mean a great deal in the game of golf. Having strong arms doesn't necessarily mean that the ball will travel a great distance when you hit it. To get the maximum distance when hitting a golf ball, you must coordinate the movements of your hips, torso, arms and wrists.

Think of your body as a whip, starting in the hips and ending in the head of the golf club. When the face of the club connects with the ball, that point of impact should be the point at which the swing has achieved its fastest motion and greatest energy. That energy is imparted to the ball by the face of the club. The greater the energy, the farther the ball will go. The smoother and more coordinated the swing, the greater the energy.

PUTTING

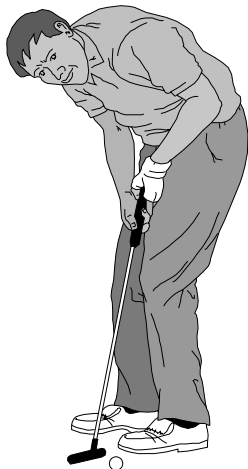

Putting is done when the ball is on the green and must now be hit into the hole. The ball may be near to, or far from the hole. Also, the green may slope off at an angle, may have rough and smooth grassy sections, and may be wet or dry. Each of these conditions will affect accurate putting.

When spectators are watching golfers on the putting green, they often think "It looks so easy!" However, this isn't usually the case. Putting is often the critical factor in a golf game. Many a golfer has lost a tournament because his or her putting wasn't precise enough.

Good putting requires a delicate touch and good judgment. There are many different styles of putting, and many different conditions on the putting green. But three things are necessary:

Keep your eye on the ball.

Keep your head absolutely still.

Move the putter along the line of the putt as if it were going through the ball.

EQUIPMENT AND CLOTHING

Different golf clubs are designed to perform different tasks. Drivers are designed to hit

the ball long distances, and are usually used on the teeing ground. Drivers are made of wood or composition material. “Irons” (which are made of plated brass and/or steel, not iron) are usually used on the fairway. Putters are used on the green.

Golf clubs have varying degrees of angles on their faces. This angle is called “loft.” The angle is measured from the vertical. Hence:

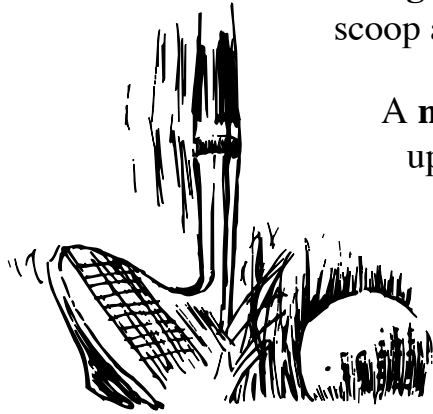

A **wedge** has the greatest loft and a very severe angle, and is used to scoop a ball out of the sand.

A **nine iron** has a large loft or angle, so it can propel a ball upwards in an arc over obstacles.

The **five iron** has less loft and a shallower angle, and is commonly used to hit the ball on down the fairway toward the green.

A **driver** has little angle and loft, and is used to drive the ball from the tee down the fairway.

A **putter** has almost no angle, since it is used for short, precise shots on the green.

A professional golfer usually owns four different wood clubs and ten different iron clubs. An amateur, however, can usually play with about half that number. A good amateur bag could carry the following clubs: Driver, Five iron, Seven iron and Putter

Golf balls weigh slightly over an ounce in weight. They are made of rubber and silicone, and other synthetic materials. The surface of golf balls are covered with tiny round indentations, spaced at regular intervals. These indentations are aerodynamic, and give the ball accuracy in flight—a far cry from the old feather-stuffed balls first used in the game!

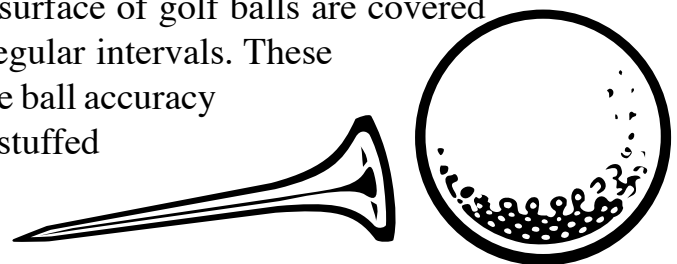

GOLF NOTES AND NEWS

One doesn't ordinarily associate golf with strong emotional experiences. Instead, golfers seem cool and detached as they walk the links. But while golf does not present the spectacle offered by football or basketball, the drama is there. 1997 offered some of the most dramatic moments ever in golf, especially with the electrifying appearance of Tiger Woods. He started the 1997 professional tour with a victory at the Mercedes Championships in January, and then went on to set the course on fire in Augusta, Georgia at The Masters. In 1998 and 1999, however, he faded a bit. But not for long.



One of golf's great accomplishments was Tiger Woods' win at Augusta on April 8, 2001. This gave Tiger four majors in a row which included the U.S. Open, the British Open, and the PGA. Woods is the only man to hold all four of golf's major trophies at the same time. In 2002, Tiger won the Masters again, making this his third Augusta win (1997, 2001, 2002). He is only the third golfer to win consecutive Masters.

With the 2006 Medinah win, Woods became the first person to win the PGA Championship twice at the same venue while also surpassing Walter Hagen on the all-time major championship win list, just six shy of the legendary Jack Nicklaus.

“It's still a long way away,” said Woods, referring to reaching Nicklaus. “It's not something I could get next year. You know, as I said, it took Jack over 20 years to get to his. It's going to take a career and I've just got to keep plugging along and keep trying to win these things.”



Sorenstam won back-to-back U.S. Women's Open Championships in 1995 and 1996. It was five years before she won another major championship, the 2001 Nabisco Championship. She successfully defended her title at the 2002 Kraft Nabisco Championship. In 2003, she won two of the four majors; the McDonald's LPGA Championship presented by AIG and the Weetabix Women's British Open. In May, 2003, Sorenstam became the first woman to play on the PGA Tour in 58 years. Sorenstam was named LPGA Tour Player of the Year and Top Tour Money Leader in 2004 and 2005. Sorenstam earned over 15 top 10 finishes and 3 victories in 2006. She also won the U.S. Women's Open Championship, in 2006.

Check out the following websites for more information about this popular sport..

<http://www.golfweb.com> <http://www.pga.com> <http://www.lpga.com>

5. Why does a professional golfer usually own many types of clubs?

6. Name three types of grips in golf.

7. Name six steps in making a smooth swing.

8. What two things are fundamental to good putting?

9. How should you warn other players of an approaching ball?

10. What should you do after you step out of a sand trap?

Name: _____ Date: _____

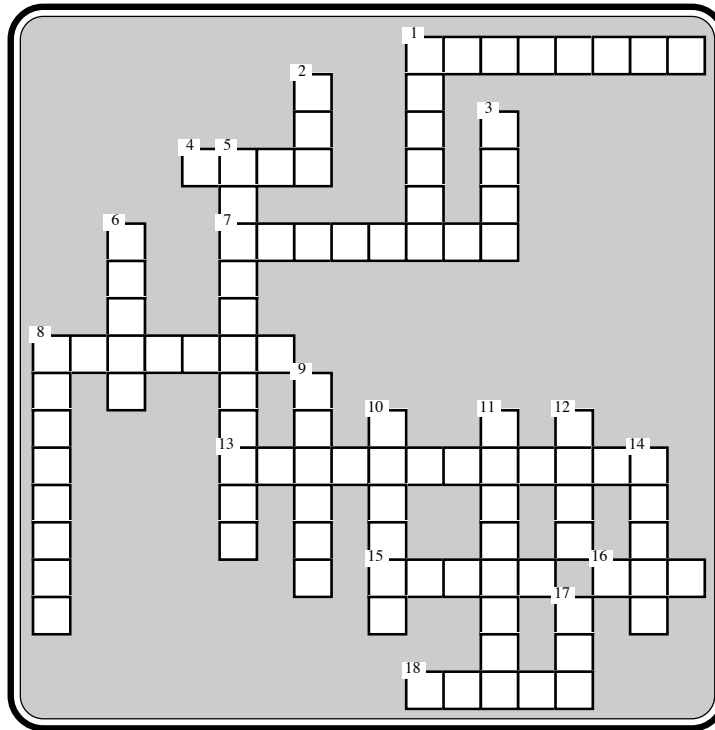

Across:

1. This grip reminds one of holding a bat
4. The number of clubs in a good amateur golf bag
7. Usual number of holes on golf courses
8. The area between the tee and the green
13. Type of grip where fingers are entwined
15. Hitting a ball into a hole two strokes under par
16. Name of gadget on which the golf ball is placed
18. The club with the greatest loft

Down:

1. Hitting a ball into a hole one stroke under par
2. Rated strokes for a particular hole
3. The first US _____ tournament was held in 1895
5. Type of grip where fingers of one hand are on top of fingers of the other
6. Hitting a ball into a hole one stroke over par
8. A fifteenth century English name for golf balls
9. This club is used on the green
10. Wood used to hit the ball off the tee
11. Where legend says golf was invented
12. The highest par rating on a hole
14. The hole is located here
17. Hitting a ball into a hole with one stroke

Name: _____ Date: _____

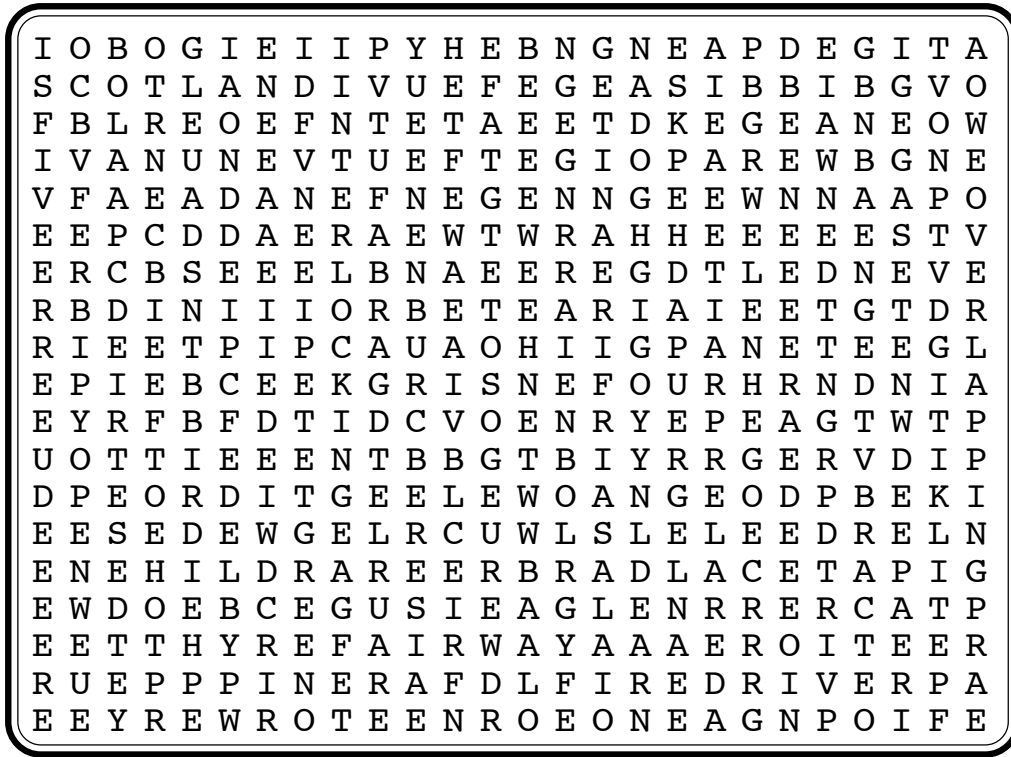

Use the clues below to discover words in the above puzzle. Circle the words.

1. Hitting a ball into a hole two strokes under par
2. Rated strokes for a particular hole
3. Hitting a ball into a hole one stroke over par
4. This grip reminds one of holding a bat
5. A fifteenth century English name for golf balls
6. Hitting a ball into a hole one stroke under par
7. The hole is located here
8. Usual number of holes on golf courses
9. Hitting a ball into a hole with one stroke
10. Wood used to hit the ball off the tee
11. Where legend says golf was invented
12. Type of grip where fingers are entwined
13. This club is used on the green
14. Name of gadget on which the golf ball is placed
15. The area between the tee and the green
16. The first US _____ tournament was held in 1895
17. The highest par rating on a hole
18. The club with the greatest loft
19. The number of clubs in a good amateur golf bag
20. Type of grip where fingers of one hand are on top of fingers of the other

INSTRUCTIONS

This Learning Packet has two parts: (1) text to read and (2) questions to answer.

The text describes a particular sport or physical activity, and relates its history, rules, playing techniques, scoring, notes and news.

The Response Forms (questions and puzzles) check your understanding and appreciation of the sport or physical activity.

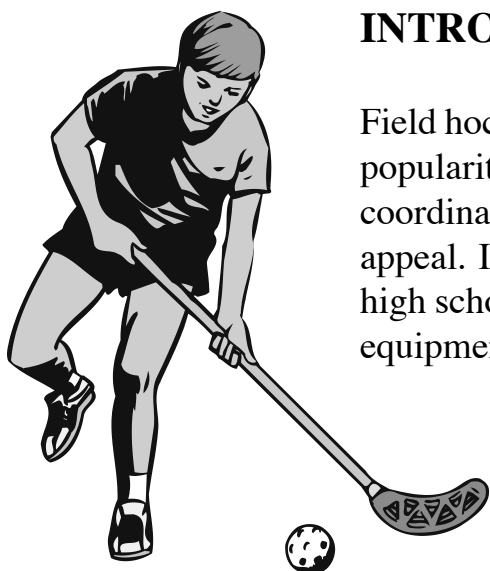

INTRODUCTION

Field hockey is a demanding, vigorous sport that is growing in popularity. It combines intense physical activity and highly coordinated team play, and has the potential for great spectator appeal. It has been somewhat slow to become popular at the high school and college level because of the expensive special equipment required.

HISTORY OF THE GAME

Hockey is thought to date back as far as ancient Greece. There is even evidence that the Aztecs played some version of hockey. Arabs, Persians and Romans all had their own version of the game.

Some believe that the word “hockey” comes from the French “hocquet,” a shepherd’s crook. Whatever its origin, the sport has been around for centuries; in fact, it is one of the oldest known sports.

By the late nineteenth century, hockey began to be played in English schools. In 1886, the Hockey Association of London was founded. British soldiers then took the game to India and the Far East. Indians were competing and winning international competitions by 1928—the year when India won the Olympic Games in field hockey. India, in fact, remained undefeated for twenty years until Pakistan emerged as a strong competitor.

Field hockey was first introduced into the United States in 1901 by an Englishwoman named Constance Applebee who taught the game to her classmates at Harvard. She was then invited to many women's colleges to demonstrate the game.

The World Hockey Cup was inaugurated in 1971. Today, the Asian Cup, the Asian Games, the European Cup and the Pan-American Games all are major international hockey events. Field hockey has been an Olympic men's event since 1908 and a women's event since 1980.

HOW THE GAME IS PLAYED

In the game of field hockey, eleven players on each team play on a rectangular grass-covered field 100 yards long and 60 yards wide. The object of the game is for both teams to move the ball into the goal cage to score as many points as possible over their opponents.

The center pass is a method for putting the ball in play at the start of the game, following halftime and after each goal. The term "bully" refers to a method used by two opposing players to restart play.

Once the ball is in play, it must be hit or touched by an attacking player's stick within the striking circle of the goal cage so that the attacking team can score a goal or one point.

Only the goalkeeper can use his or her feet or body or the stick to stop a ball. Other players can use only the flat surface of the stick to move the ball. However, they can stop the ball with their hands. The stick can never be raised above shoulder level (see section on "Fouls" below).



Five forwards, three halfbacks, two fullbacks and a goalkeeper make up the team. A game is made up of two 30 minute halves. There is one five-minute break with time out called only for an injury.

FOULS

Various types of fouls occur in field hockey. Fouls are called by one of the two umpires who are positioned on the two halves of the field. Most fouls are penalized by allowing

the opposing team a free hit.

Here are some of the most common reasons for fouls:

1. Raising the stick above the shoulder during a game.
2. Advancing the ball with the hand (as opposed to stopping it, which is legal).
3. Hooking or grabbing an opponent's stick with another stick.
4. Undercutting, or causing the ball to rise so high that it becomes dangerous to others.
5. Coming between the opponent and the ball by putting a stick or some body part between the opponent and the ball (the obstruction rule).

PLAYING TECHNIQUES

ATTACKING SKILLS

When a team has control of the ball, many different techniques can be used to the offensive team's advantage. Six major techniques are as follows:

1. The **Drive**. This is a method of passing the ball to a teammate. The stick is lifted waist-high while on the downswing, and the left arm pulls the stick as the right arm pushes it. This move is usually spontaneous and is done on the run or is "walked into." There's usually no time to prepare to hit.
2. The **Dribble**. This move is made by gently tapping the ball along. While it looks and sounds easy, it takes practice to do it correctly. The stick is carried to the right-hand side of the player's body with the elbows slightly bent. The player who is dribbling should keep his/her eyes on the ball and on the other players on both teams.



3. The **Scoop**. This technique often accompanies the dribble. It allows the player to scoop the ball far enough off the ground to clear the opponent's stick. It requires little backswing and little, if any, follow-through. It should be a gentle, lifting motion resulting in a reaching stroke. The ball is ahead of the supporting foot as the player reaches for the ball with the stick.
4. The **Flick**. This is also a reaching stroke with the ball ahead of the forward or supporting foot. This move puts a spin on the ball and can make it travel a considerable distance. However, the negative side of this move is that a spin can make it as difficult for a teammate to receive the ball as for an opponent to block it.
5. The **Push**. This move is used for short passes. There is no backswing on this move and both arms are working in the same motion. The move must be made quickly because as the player pushes the ball, the player's weight moves onto the toes of the forward foot.
6. The **Dodge**. "Dodging" is a general term applying to moves that are not passed and not used for shooting. The dodge is a method of avoiding or escaping an opponent while the player continues with the ball.



SCORING GOALS

Being in good physical condition and having a good grasp of the game are of prime importance in field hockey. However, an aggressive player also wants to make the most goals possible. Field hockey participants eventually learn that being persistent on the field wins games. In addition, it helps to observe these tips:

1. Make your attempt at the goal cage from a distance that's not too far away from the cage.
2. Aim at a specific spot in the goal cage, not just in the general direction of the goal.
3. Aim for the area left open by the goalkeeper. Remember: the goalie cannot be everywhere at once!

4. If it's not possible to attempt a goal, pass the ball to a teammate.

EQUIPMENT AND CLOTHING

One reason for the slowness with which field hockey has caught on at the high school level is the expense of furnishing the necessary equipment. Players need not only special clothing and equipment, but also a specific type of goal cage.

The hockey stick is usually 36 inches long and weighs from 12 to 28 pounds. The weight of the stick increases as the length increases. Only the flat side (left side) of the stick can be used to strike the ball.

Sticks require careful treatment in order to make them last. They need an occasional sandpapering and rubbing with wax to keep them from splintering.

Today, balls are made of leather or plastic and can be any solid color as long as the color contrasts with the playing surface. (instead of the older cricket balls).

Beginners can use tennis shoes to play field hockey. However, more advanced players and professionals use rubber-cleated hockey shoes. The cleats help players to stop, start and maintain balance on wet, mushy fields.

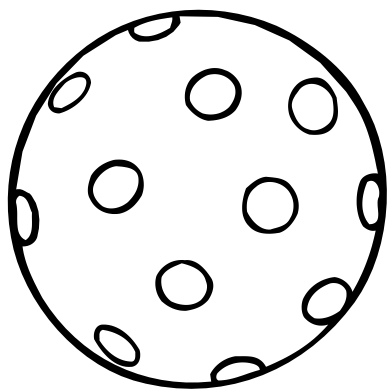
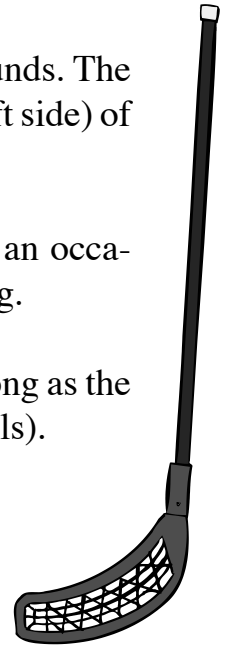

The goalie wears the heaviest, most cumbersome uniform of anyone on a hockey team. He or she wears protective padding and padded gloves to stop the sting of a fast ball. Goalies also wear shin pads (as should other members of the team).

The goal cages are also vital pieces of equipment in this game. They are four feet deep and four yards wide by seven feet high. Although older cages were difficult to set up and take down, modern goal cages are made of lightweight aluminum and are portable.

NOTES AND NEWS

Field hockey has never had the popularity in North America that it enjoys in other countries. In India, for example, field hockey is the most popular sport in the country. Popularity is sometimes a guide for predicting performance.

As the National Governing Body for the sport, the United States Field Hockey Association prepares teams for participation in the Olympic Games, Pan American Games, World Cup and many other international competitions. The U.S. Field Hockey elite team programs include both national and age group squads for both men and women.

2004 Olympics at Sydney, Australia

	Men's Team:	Women's Team:
<i>Gold Medal</i>	Australia	Germany
<i>Silver Medal</i>	Netherlands	Netherlands
<i>Bronze Medal</i>	Germany	Argentina



2006 NCAA Championship

No. 2-ranked Maryland used a suffocating defense and a lone first-half goal to beat No. 1 Wake Forest 1-0 and win its second consecutive NCAA field hockey championship. Maryland, 23-2, scored the only goal of the game with just under five minutes remaining in the first half when senior Emily Trycinski tapped in an unassisted goal. Trycinski emerged from a scramble near the goal and poked the ball past Deacon goalkeeper Crystal Duffield at the 30:08 mark.

“I was just lucky to be in the right place,” Trycinski said. “It’s crazy. I did not expect it (hitting the game-winner) at all.”

Trycinski’s goal was a rare offensive highlight in a game dominated by defense. The two teams combined for just 11 shots, breaking an NCAA Tournament finals record for fewest shots.

Field hockey is exciting to play and watch. Take advantage of opportunities to do both. Find out why other countries are so involved in this sport. Visit these web sites to learn more:

<http://www.ncaasports.com/fieldhockey>

<http://www.fieldhockey.com/>

<http://www.planetfieldhockey.net/index.php>

STUDENT RESPONSE PACKET

FIELD HOCKEY

NAME _____

DATE _____

WHAT TO DO

The following questions will help you to have a greater appreciation and understanding of field hockey. Write your answers in the spaces below the questions. If there is not enough room, write on the backs of these sheets. Be neat, spell correctly, and write in complete sentences.

1. What are the physical benefits to be gained from playing field hockey?
2. How many persons comprise a hockey team? What positions do they play?
3. What does the term “bully” mean in hockey?
4. True or False: All the players on a hockey team can use their feet or bodies or the stick to stop a ball.

Name: _____ Date: _____

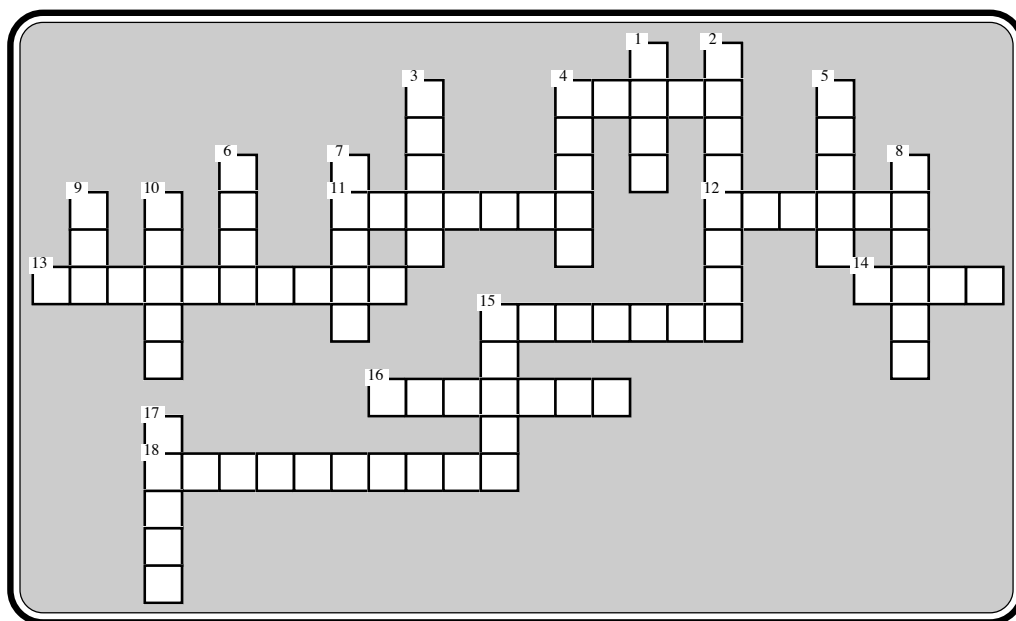

Across:

- 4. Lifting the ball off the ground
- 11. French word for shepherd's crook
- 12. Number of players on a hockey team
- 13. This team member can use feet, arms and body to stop the ball
- 14. Method of making short passes
- 15. Moving the ball short distances
- 16. There are this many yards in a field hockey field
- 18. The number of minutes in a half

Down:

- 1. Advancing the ball with the hand is one
- 2. She taught field hockey to her students at Harvard in 1901
- 3. Putting spin on the ball
- 4. Width in yards of a field hockey field
- 5. Passing the ball to a teammate
- 6. Number of forwards on a hockey team
- 7. There are this many halfbacks on a team
- 8. Time out is called in case of one of these
- 9. The number of fullbacks on a field hockey team
- 10. A method by two players to restart play
- 15. Move that does not included either passing or shooting
- 17. Players use this important piece of equipment

Name: _____ Date: _____

Physical Education 10 Word Search



Use the clues below to discover words in the above puzzle. Circle the words.

1. Number of players on a hockey team
2. Advancing the ball with the hand is one
3. Number of forwards on a hockey team
4. This team member can use feet, arms and body to stop the ball
5. She taught field hockey to her students at Harvard in 1901
6. Width in yards of a field hockey field
7. Move that does not included either passing or shooting
8. French word for shepherd's crook
9. The number of minutes in a half
10. Time out is called in case of one of these
11. Putting spin on the ball
12. A method used by two players to restart play
13. There are this many halfbacks on a team
14. There are this many yards in a field hockey field
15. Method of making short passes
16. Passing the ball to a teammate
17. Moving the ball short distances
18. The number of fullbacks on a field hockey team
19. Players use this important piece of equipment
20. Lifting the ball off the ground

INSTRUCTIONS

This Learning Packet has two parts: (1) text to read and (2) questions to answer.

The text describes a particular sport or physical activity, and relates its history, rules, playing techniques, scoring, notes and news.

The Response Forms (questions and puzzles) check your understanding and appreciation of the sport or physical activity.

INTRODUCTION

Baseball is probably the one sport which is most clearly identified with “being American.” Former President Herbert Hoover once stated that baseball is the greatest of all team sports. For the past 150 years, baseball has become so intertwined in all aspects of American daily life that the baseball strike of 1994 seemed almost unthinkable. Who could imagine summer without hot dogs and soft drinks at the ball park or a warm summer evening spent cheering a favorite team to victory?



HISTORY OF THE GAME

Baseball, however “American” it may seem to us today, did not originate in America. It probably began in England with a game called “rounders.” The term “baseball” dates from 1744, when a book on sports described and illustrated a batter holding a bat with a catcher in position behind the batter and a pitcher ready to throw a ball. This English book was reprinted in America around 1762.

In 1845, an American amateur baseball player named Alexander Cartwright, along with other early baseball players, wrote the rules of the game. Many of these rules are still in effect today.

Baseball came to be dominated by professional players some time around 1869, when the first professional team, the Cincinnati Red Stockings, was organized. Later, many regional leagues were started, then dissolved. At this point in history, baseball was not a very lucrative business, and few teams were able to make money. In the late 1880s, the National League attempted to limit the salary that players could accept to a maximum of \$2,000.

During the early period of league formation, rules for transferring players from one league to another were created. There were also strict rules for recruiting minor league players for the major leagues. At present, all major league teams maintain minor league teams called “farm clubs” where players are trained and eventually transferred to a major league.

In 1903, the first World Series was held. It was held every year since until the baseball strike of 1994. Today, baseball, despite the impact of the strike, continues to be a highly-organized and lucrative sport. The salaries of baseball players are the highest of all athletes who play team sports.

HOW THE GAME IS PLAYED

THE RULES OF THE GAME

In baseball, two teams of nine players compete with one another on a baseball “diamond” which in reality is a square field. The teams are comprised of a pitcher, catcher, a first, second and third baseman, a shortstop, and left, center and right fielders.

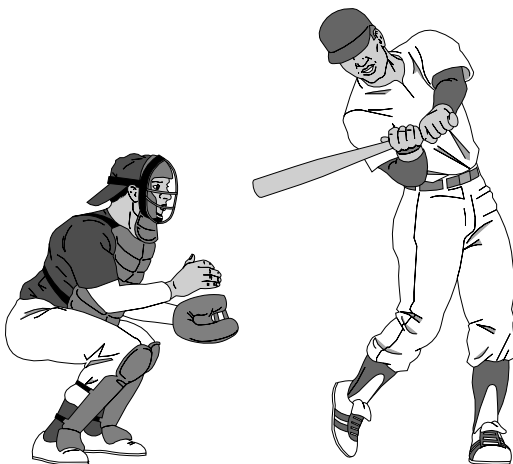

A catcher stands behind the batter and signals the pitcher as to what type of ball to throw. Each game is made up of nine innings. If the home team is ahead (that is, if it has scored more runs) at the end of the middle of the ninth inning, the home team wins.

The baseball field has four bases which are spaced ninety feet apart from each other. The batter's box, the area where the batter stands, is located 60 feet and six inches from the pitcher's mound. The two foul lines run the length of the field and define the playing area.

The batter's objective is to get a hit. Once the ball is hit, the batter (now called the "runner") must get to first base before the ball is caught by the first baseman. Once the ball is caught, the runner is tagged or the first baseman touches first base before the runner touches it. If the batter can get to first base safely, it is called a "single."

A "double" occurs if the batter can run to second base, and a triple occurs when a batter makes it to third base. A home run means that the batter runs around all the bases and reaches home plate ahead of the ball. The batter can also hit a home run by hitting the ball over a wall or fence in the outfield.

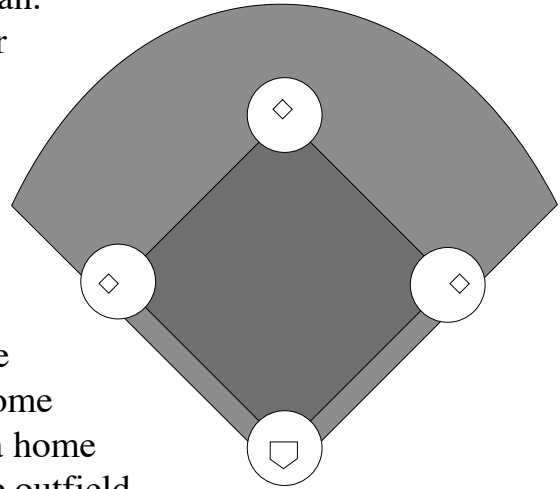

The defensive team in the field tries to keep the offensive team's batters from scoring. One way of getting a batter out is to pitch three strikes. A strike occurs when the batter swings and misses or doesn't try to hit a ball that is pitched within the strike zone. If a batter already has two strikes and hits a ball into foul territory, the foul does not count as a strike. A foul ball counts as a strike under all other conditions.

If a pitcher throws a ball that does not cross home plate between the batter's armpits and knees (the strike zone), the pitch is "a ball." When a pitcher throws four balls to any one batter, the batter is able to go to first base without having to hit the ball—technically called "a walk."

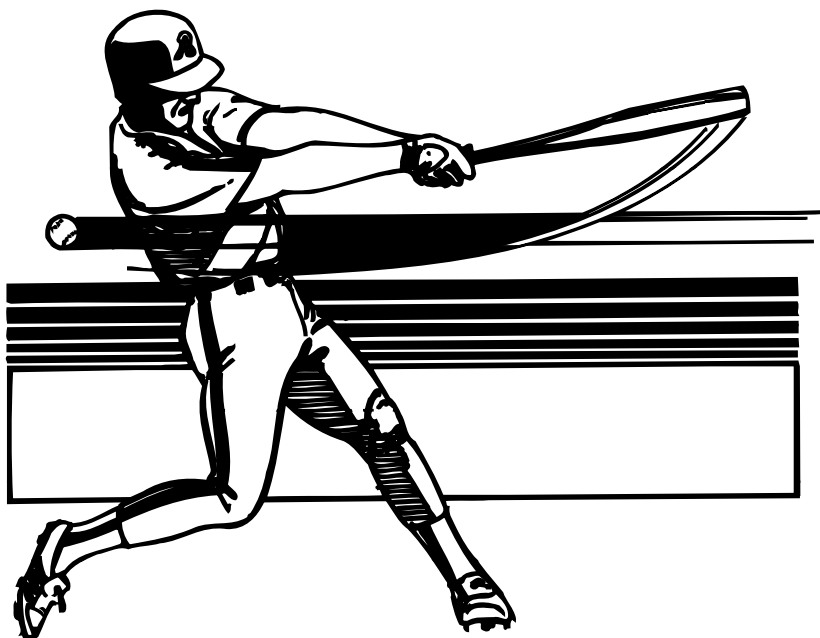

Once the ball is hit and is in the air, the players in the field attempt to catch the ball before it hits the ground. If a fly or line ball is caught, the batter is automatically out. A ground ball, when caught, is thrown to a base in order to get the runner out.

Baseball players can also slide into a base to keep from being tagged out. Sliding is more

difficult than it appears to be and requires practice to be done properly. The body falls to the ground in a controlled manner by a fall backward on the outer surface of the knee and lower leg, or just by diving head first.

All games have at least one umpire to call balls and strikes. Major league games have four umpires, one at each base.

THE PITCHER

The pitcher is considered the most important defensive player on a team. This position is the most physically demanding spot on the team as well as the position with the most control over the game. A pitcher needs excellent control over the ball in order to throw the ball where he or she aims it. Pitchers have been known to throw the ball 100 miles per hour.

Various styles of throwing the ball may be used to achieve different results. For example, a curve ball swerves from a straight line to the left or right, depending on which arm the pitcher is using. A fast ball is just that—a ball thrown extremely fast. A “slider” is a cross between a fast ball and a curve ball and seems to “slide” away from the batter.



OUTFIELDERS AND INFIELDBERS

Long or high balls, or ground balls that go past the infield, are caught by one of the three outfielders. Outfielders must have superior throwing ability. The center fielder is generally the fastest of the three outfielders since he or she has the most area to cover. Center

fielders must also have a “strong arm,” as they must throw balls to third base and home plate. Some of the most famous names in baseball were outfielders—among them Babe Ruth, Ty Cobb, Joe DiMaggio, Ted Williams and Mickey Mantle.



The job of the infielder, the player who is on the bases and the shortstop, is to try to prevent balls from going into the outfield. These players also attempt to throw or tag out the batter once a ball has been hit. In particular, the short-

stop has the most demanding position and must have a strong throwing arm and quick reactions.

The history of baseball is full of famous infielders, including Lou Gehrig, Rogers Hornsby, Jackie Robinson and Ernie Banks.

THE CATCHER

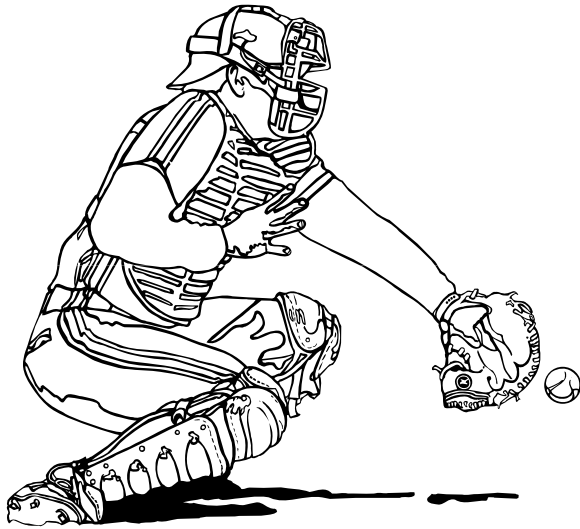

The position of catcher is considered to be very important. The catcher is the “brains” or strategy planner for the game. His or her judgment in choosing pitches can determine the best defensive play for the rest of the team.

The catcher is thought by many to be the hardest-working member of a team. He or she has to know all the weaknesses and strengths of the pitchers. He or she covers third or first base when no one else is on base, and wears more equipment than any other player.

DESIGNATED HITTER

A tenth starting player in the American League, minor leagues and many amateur leagues is a player used only to bat. This player has no defensive role and bats instead of the weakest hitter (usually the pitcher).

KEEPING SCORE IN BASEBALL

The box score (records of both individual players and games) is kept by an official scorer. Also, newspapers and baseball clubs keep detailed records of the players’ batting averages, fielding averages and pitching records.

Batting averages are calculated by taking the number of hits and dividing that figure by the number of times a player is at bat. If a batter “walks,” it is not counted as a time at bat. Nor is it counted as a hit. Fielding averages are figured by taking the total put-outs and assists and dividing them by the total number of put-outs, assists and errors.

An error occurs when a player gets to first base because the defensive player did not

catch the ball or, having caught the ball, threw it poorly to another player.

Pitching records indicate the number of games won and lost and earned-run averages (total earned runs allowed, divided by the number of innings pitched, then multiplied by nine).

PLAYING TECHNIQUES

THROWS IN BASEBALL

Developing a good throwing technique is an important skill in baseball. Throwing is the most complicated of all the baseball skills to execute effectively. It calls for speed, accuracy and long hours of practice. Good throwing takes into account the following steps:

The first step in learning a correct throwing technique is a proper grip. The player should grip the ball by placing the index and middle fingers over one of the four long seams on the baseball. The inner side of the thumb is placed on the underside of the ball in line with the middle finger. The ball and the point where the index finger and thumb meet should form a “V” shape. The ball is held loosely, almost in the fingertips.

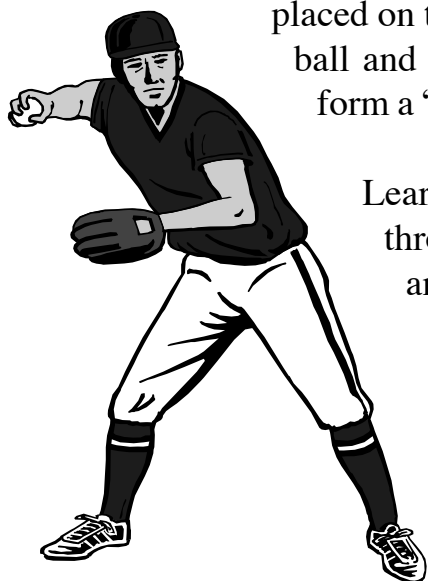

Learn the proper stance for throwing. As the player prepares to throw the ball, his or her elbow should be up, shoulders level, and wrist cocked with fingers behind and on top of the ball. As the ball is released from a point over and in front of the player’s head, the player’s fingers should be behind the ball.

Remember that a player’s arm does not work alone in throwing the ball. The player’s entire body needs to be propelled forward in order to build arm speed for the throw. The player needs to take an exaggeratedly long step forward toward the target. The length of that step, however, depends on how far the ball has to travel. For example, an outfielder’s step will be long because he has to throw the ball up to 300 feet away.

Follow-through is important! The technique of throwing does not end when the ball is released from the hand. If there is no follow-through, the ball will lose a great deal of speed and accuracy. The throwing arm should continue

to move downward across the front of the body and behind the left hip if the right arm is being used. Both feet should be parallel to the target and pointing toward it.

Players need to take special care of their arms because of the intense workout the arm gets in a game of baseball. Warm-up exercises should always be done before practice or a game. Many players ruin their chances at a pro or amateur career in baseball by abusing their arms. Watch that arm—it is your most valuable asset in the years of baseball playing ahead of you!

EQUIPMENT AND CLOTHING

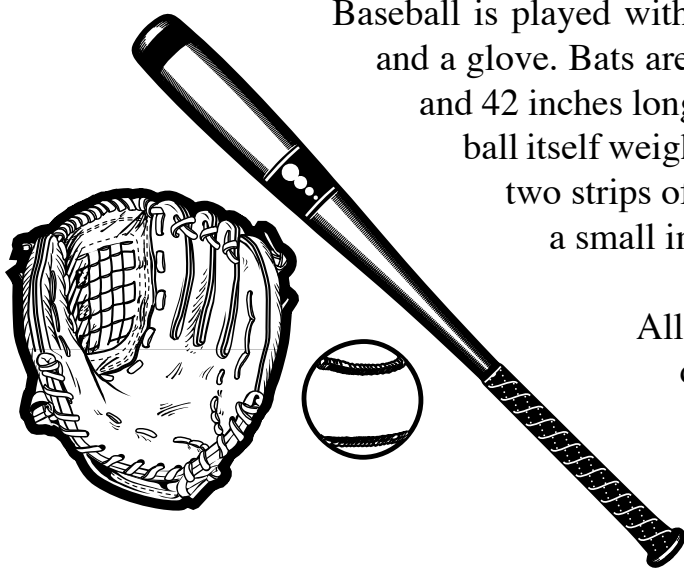

Baseball is played with very simple equipment—a ball, a bat and a glove. Bats are no more than 2-3/4 inches in diameter and 42 inches long. They can be of any weight. The baseball itself weighs about five ounces and is covered with two strips of white horsehide stitched together with a small inner core of cork or rubber.

All players on a team use gloves. A standard baseball glove may not exceed 12 inches in length and 8 inches in width. The first baseman and catcher usually wear gloves that are thicker than those of the other players.

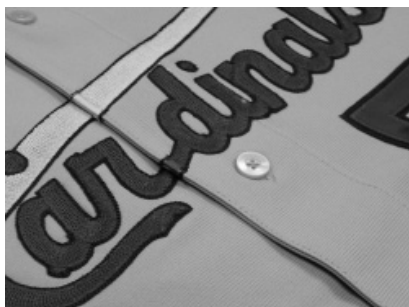

BASEBALL NOTES AND NEWS

In October of 2006, the Cardinals won their first Series title since 1982 by completing a five-game domination of the Detroit Tigers with a 4-2 validation at Busch Stadium.

Starting pitcher Jeff Weaver, a July acquisition deemed not good enough by the Los Angeles Angels, offered a nerveless performance to further belie his New York-given reputation as a weak-kneed autumn arm.

Shortstop David Eckstein ended a World Series that began with 11 hitless at-bats by accounting for his team's first two RBIs in game five and acknowledgement as Series MVP.



“We did not stay in the past, and we weren’t looking toward the future. We stayed in the moment,” said Eckstein, who finished with a .364 overall average to go with six hits and four RBIs in the Series’ final two games.

A bullpen thought destitute after the Sept. 7 loss of closer Jason Isringhausen again provided the final punctuation point, this time with rookie Adam Wainwright finishing it with a three-pitch strikeout of Tigers third baseman Brandon Inge.

The Cardinals didn’t just win their 10th World Series. They emerged from a disconsolate 83-win season, a 12-17 September and a near-calamitous final two weeks to outdo the 85-win 1987 Minnesota Twins for translating the fewest regular-season victories into a championship.

“We tasted a lot of failure this season,” said third baseman Scott Rolen. “I can tell you this tastes a lot better.”

The Cardinals won simply. They outplayed a team that for much of the season led both leagues in wins. When it was done, the Tigers had scored 11 runs and committed eight errors. The Cardinals, who endured a losing record for the season’s final five months, scored 22 runs, committed four errors and never looked down during an 11-5 October.



The Tigers, who steamrolled through the first two rounds, never seemed themselves after the week-long layoff. The top three spots in their batting order hit just .103, the second-lowest in World Series history. Placido Polanco, the MVP of the ALCS, was hitless in 17 at-bats. And their vaunted bullpen, considered perhaps the best in baseball, gave up seven runs and eight walks in 7½ innings in their final three losses.

“I just only hope that nobody forgets the job that we did,” Leyland said, “to go from 71 wins to the World Series. I just hope that nobody just totally writes us off that we’re not a good team, because we are. We played very well in the postseason until this World Series.

“We have no excuses. We got beat by a team that played a lot better than we did during the course of the series. ... I’m responsible and I accept that responsibility. It’s my job to have my team ready. We just didn’t do enough things.”

The Tigers instead could only watch the Cardinals play nearly flawless baseball. They executed the fundamentals. Produced the clutch hits. And yielded a meager 2.05 ERA.

For the first time in 24 years, the Cardinals are October's story.

Baseball is also an Olympic sport. The 2004 Olympic results at Athens were:

Gold: Cuba
Silver: Australia
Bronze: Japan

For more information visit these web sites to stay informed about baseball:

<http://www.sportsline.com/u/baseball/college/index.html>

<http://www.majorleaguebaseball.com/>

<http://www.baseball.com/>

STUDENT RESPONSE PACKET

BASEBALL

NAME _____

DATE _____

WHAT TO DO

The following questions will help you to have a greater appreciation and understanding of baseball. Write your answers in the spaces below the questions. If there is not enough room, write on the backs of these sheets. Be neat, spell correctly, and write in complete sentences.

1. Baseball is often identified as the great American sport, yet it didn't begin in America. How and where did this game originate?
2. What are some of the physical benefits to be gained from playing baseball?
3. What are "farm teams" and how are they used?
4. How many people make up a typical baseball team and what positions do they play?

5. What is a “single”? a “double”?

6. When does a “ball” occur?

7. How is a good slide into a base performed?

8. Why is the pitcher considered the most important defensive player on the team?

9. Name at least four factors involved in performing a good throw:

10. What are some of the effects of the baseball strike in 1994? In your opinion, will baseball ever return to its pre-1994 status as the most popular spectator sport in America?

Name: _____ Date: _____

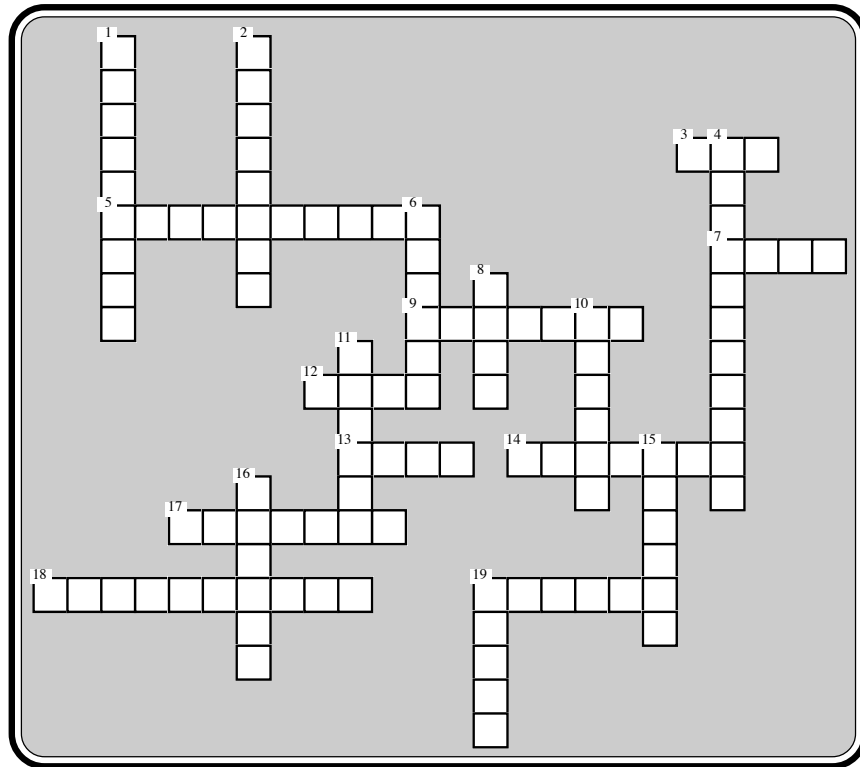
**Across:**

3. The batter stands in it. It is 60 feet 6 inches from the pitcher
5. They are the players who try to prevent ball from going into the outfield
7. Weight in ounces of a baseball
9. Nickname for a baseball field
12. The number of bases
13. If the ball is not pitched in the strike zone and the batter does not swing, it is called this
14. The player who gives signals to the pitcher to tell him what type of pitch to throw
17. Most consider him to be the most important defensive player
18. Wrote the rules of baseball in 1845
19. A hit that gets the batter to first base safely

Down:

1. The first pro baseball team was the Cincinnati Red _____
2. What baseball used to be called in England
4. They are the players who are responsible for catching long fly balls
6. A cross between a fast ball and a curve ball
8. Another word for a minor league team
10. The distance in feet between the bases
11. A hit that gets the batter to second base safely
15. This player takes a position in the batter's box
16. When the batter swings at a pitch and misses it
19. A method of touching the base without being tagged out

Name: _____ Date: _____

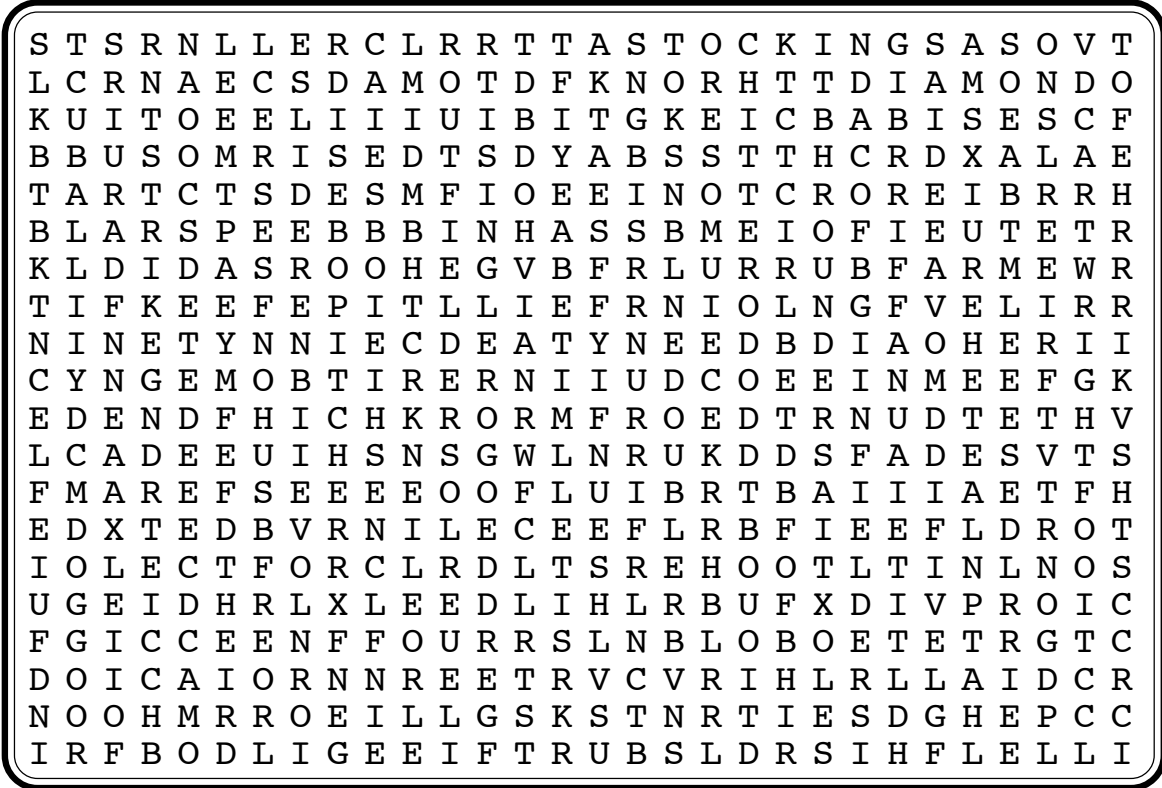

Use the clues below to discover words in the above puzzle. Circle the words.

1. They are the players who try to prevent ball from going into the outfield
2. The distance in feet between the bases
3. The number of bases
4. A hit that gets the batter to first base safely
5. Wrote the rules of baseball in 1845
6. Another word for a minor league team
7. The batter stands in it. It is 60 feet 6 inches from the pitcher
8. When the batter swings at a pitch and misses it
9. Most consider him to be the most important defensive player
10. Nickname for a baseball field
11. This player takes a position in the batter's box
12. A cross between a fast ball and a curve ball
13. They are the players who are responsible for catching long fly balls
14. What baseball used to be called in England
15. The player who gives signals to the pitcher to tell him what type of pitch to throw
16. A method of touching the base without being tagged out
17. Weight in ounces of a baseball
18. If the ball is not pitched in the strike zone and the batter does not swing, it is called this
19. A hit that gets the batter to second base safely
20. The first pro baseball team was the Cincinnati Red _____

Physical Education 1 Answers

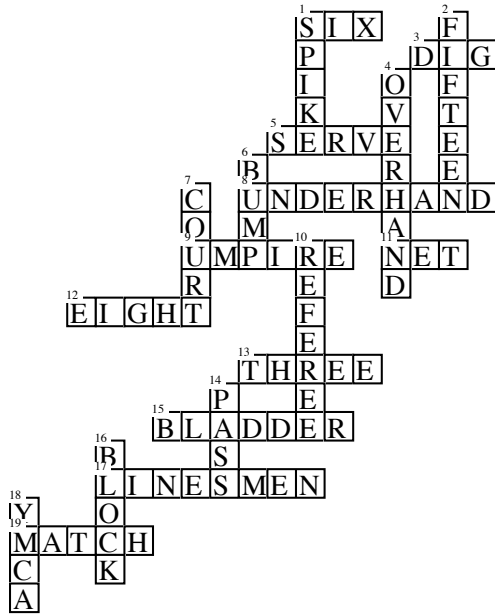

1. Why is volleyball considered to be such a good aerobic exercise?
Volleyball is fast-paced with constant jumping and running.
2. How many total points can be scored in a game of volleyball?
The total number of points in rally scoring is 25 with a 2 point advantage needed. Ties in this game are played to 15 and a 2 point advantage necessary. With traditional scoring, 15 is the total points needed to win a game with a 2 point advantage required.
3. What does “a match” in volleyball consist of?
A match consists of winning two of three 15 point games.
4. What clothing is typically worn for playing volleyball?
When played indoors, sportswear and gym shoes are worn. When played on a beach, attire ranges from gym clothes to swimsuits.
5. What is “the ready position” in volleyball and how is it used?
A position where the knees are slightly bent with hands at waist level and elbows near the body.
6. What is an overhand serve?
This is the most popular and effective serve. The ball is thrown into the air and the server hits it over his or her head.
7. What is an underhand serve?
This is a good beginner serve. The ball is lightly tossed into the air with one hand and hit by the heel of the other hand.
8. What is a pass and how is it used?
A pass is made to a player on the same team and is often made to set up a spike.
9. How is a spike ball hit?
A spike ball is hit with the heel of the hand. It is a powerful hit with no arc. The player’s hand is above the net when the spiked ball is hit.
10. How is a block used?
This move is used chiefly to stop spiked balls. Timing is important in blocking.

Physical Education 2 Answers

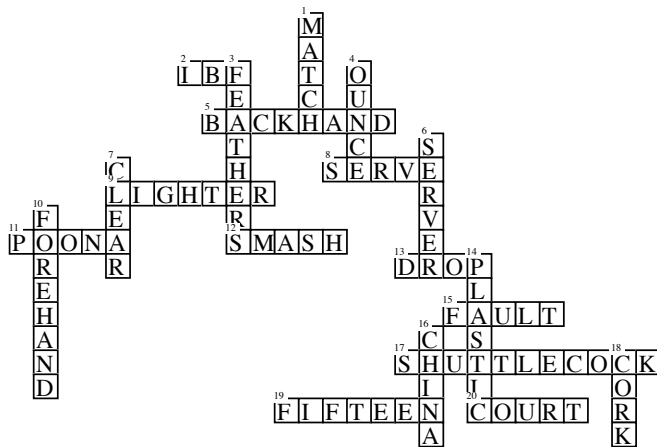

C S H B H V E F O R E H A N D K N H T C F E A F R E P R
 C A I R E P B C C I A O O D O A C G N P U A O N A E M A
 S T C C O U R T A P M A T C H R F I C O R K E R I N A H
 C K A H I R E E L L N P H F O E O P U R C R T I T E N T
 R H F F S A N M A E T R R A A I O A A B O B C K A C U R
 G A I E F C L I G H T E R T E E O V O E C S R A E F A I
 B U D N F I F T E E N F C F E A T H E R S C E F O U S A
 E F T D A T E I K O C L H M E C C P C R R S P R L A O R
 E P N C E S C S E A M E L O I E K B R H O B L A V R E R
 N S O S S O N L E H E E R C R R C A E N D P F C C E H R
 O O F O F F U T E R K C G H S N M O I F C P O R D O R E
 N R B F N O B R O A V U E L M N E I O O R L O P R E R C
 E H T E S A R A E O R E L H E H C B S C E A M K O T R S
 L F A U L T C S C E K D I E F B M F M N S S T B P S E R
 M R S P O O A E T K D O O O R H T K A K F T C E I R R L
 R H S E K E U L N F H B E O S T N T S E B I D A A E T S
 S O E L T T S N T A T A E E D I R I H T N C I B C E R H
 R S H U T T L E C O C K N A V R O E A F P I E K R I E B
 I C S F S R I C T E H I T D C N R M O H C U E A D R C D
 E O O A R C S O L R O N A L U E L T P C P T S L A T T N

- Why is badminton a good game to help maintain and improve physical fitness?
This game demands intense concentration and players must jump, run, turn and twist. Badminton provides good aerobic exercise.
- What equipment is needed to play badminton?
Badminton requires a racquet and shuttlecock.
- Who can make points in a badminton game?
The server is the only player who can make points.
- How is a badminton game won?
The side first to accumulate 15 points wins the game. Sometimes players play until one side has 21 points.
- Describe a forehand shot.
The basic forehand shot is similar to throwing a ball - the hand flexes at the wrist.
- What is a smash shot?
This shot is the ultimate “attacking” shot and requires a powerful arm stroke.
- What is a drop? a backhand drop?
The drop is a controlled smash shot. A backhand drop is played the same as the clear and smash shot.
- When is a forehand drive used?
This shot is used when the shuttle is too low to smash.
- What is especially tricky about the forehand underarm clear?
This shot is like hitting a high serve, only it is hit lower. The player lunges forward with front knee bent and he or she leans toward the shuttle.
- True or False: Badminton is an Olympic sport.
True.

Physical Education 3 Answers

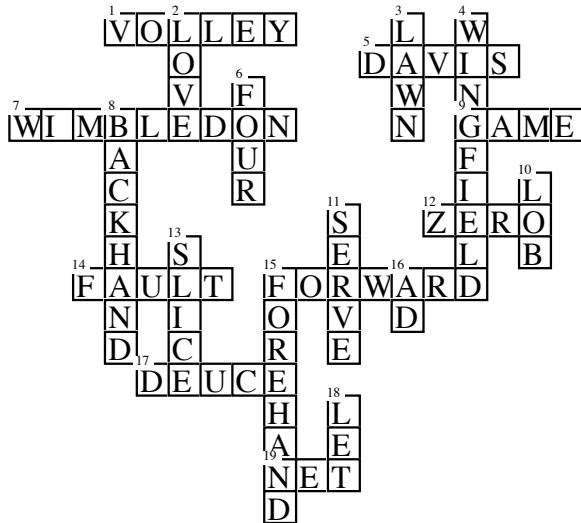

E W N E E E L D E L U E N E E F O I L E D O Z E L O G B H
W L D D E E E A R E D E E V A S B A B U V R E L A A T R R
E E G H G L B V T C E U D L B T N E C E Z E R R N E L L L
A D S F D C L F U L S N N E L E E N T D L A O A D R L F V
Z V T I S T F O R E H A N D U I T E O R A M L N R E A L N
F W E Y L L O A E C T E L A A C L T I E O L B U F W E D L
E I E A I T U O M L L V A O F N E D F E T R D O R E U L V
A M D M C R O U A A L O O L G A Y U S G O W F B B L E V N
Y B N F E B N N Z B O T R O E Y U E F O D O L F A F A O O
F L L E O W A W I N G F I E L D L O B H R D T O Y D F L L
A E R L T R L C E F B R N A R S V O L L E Y O T E M F L A
U D L A C L W L K U O R V O A A F E F W E L L L D W T U W
L O R G M D N A L H D U W A L L O R L M R M E D E B N N N
T N U A Y O E A R O A C R F B T L Z S E N E R I E T L E A
L R U M B U L V L D K N O O E R S O Y W R E D F R O O S E
M L N E S E A B V A B A D E R B E E D B L G L V N D D E D
E R E N V I A O D F B Z E D A O E A R A E N O V L D E A L
D A L E F W D B D R U T L F D I A E N V E L V V R O I L T
I R A D A V I S T A Z E O B A T A I W E E D E E F E E A N
F D V D U C L U D F N T O L D O O A E O L E E E E O F F I

1. What are the physical benefits of playing tennis?
Tennis is an excellent aerobic sport providing cardiovascular benefits.
2. What is a “fault” in tennis?
A “fault” is committed when the server hits the net with the ball and it goes out of the service area during the serve.
3. What is a “let ball?” a “net ball?”
A “let ball” is a serve that hits the net but lands within the service area. A “net ball” is when the ball hits the net during play.
4. When and where was tennis first played?
Major Walter C. Wingfield introduced tennis to Britain in 1873. A version of tennis is believed to have been played in Greece and in France in the 1400s.
5. Name the four types of serves in tennis.
The four types of serves are: the flat serve, the slice serve, the kick serve and the American twist.
6. What is the tennis volley and how is it executed?
The volley should be a short and simple shot with the player’s knees bent and legs slightly apart.
7. What does the score “love” mean in tennis?
The score “love” means zero.
8. What does “a set” in tennis mean?
A set in tennis is won when one side has won six games and is leading the other side by at least two games.
9. What is the first point in a tennis score?
The first point in tennis a tennis game is 15.
10. What comprises “a match” in tennis?
A match in tennis means one side has won at least two sets.

Physical Education 4 Answers

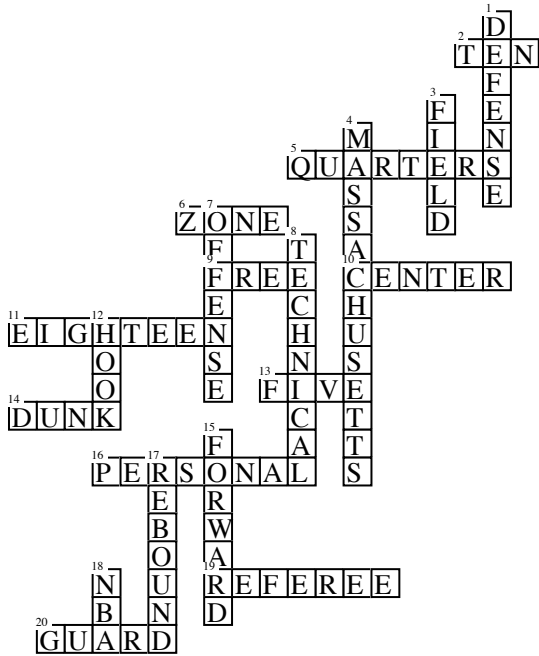

V D E F E N S E A N N R R R Q O E C Z S T E C H N I C A L U
 L O E D F I E L D E E T E I F C E N T E R R S I H E D N N
 I E O T B E I G H T E E N R T F N R O R T E H O O K B F B
 U A L E N I S A S N O E E F N O A L R A N E K F D I T M A
 K T B E O E I U B E R T N C C R E F E R E E F I E N A R F
 F O E S F U P E R S O N A L R E R E B H O F A O V N N N L E
 R O W Z F N E S M E F O I C M A S S A C H U S E T T S T E
 E A I T E C R O D N S E K H R E S D R E T H L F E O F T B
 E W E B N E G R S L O T U Q E A A F F O E E N H P O F D B
 Z I F R S P E R N Z O N E Z I R E B O U N D E D R F S E E
 V U N E E G S S R Z E E R B G F V L R O F E T H O D E E A
 A N E E T D E E S E Q U A R T E R S N E A O E K E U O T E
 U T G R K C F N F T P N N F D U T G F S V R I R N N T E H
 N R G U T F O R W A R D F A E R E H E E F E A R Z K S E E
 K B U D A E D F S R E E P L R R N B R T E H D F E U E O N
 R T A N F R N T E E F I T I D B Z T E E V I R R K N I R R
 E G I E K R D N R D R O D R N A W D O F E N H L N D D N E
 N A R A N H T S K L E E E L C U S E D K T O R U R M T O E

- What are some of the physical benefits of playing basketball?
There are cardiovascular benefits from playing this sport because the game requires much running and jumping.
- True or False: More people watch basketball than any other sport in the United States.
True.
- What is the object in any game of basketball?
Players try to score points for their team while preventing opponents from making baskets.
- What comprises a team in basketball? How many players and what positions?
There are five players - a center, two forwards and two guards.
- How does any game of basketball begin?
The game begins with a jump ball.
- What is a field goal?
A field goal is when the ball is put into the basket during the course of the active game. It can be worth either two or three points.
- Name at least three types of shots.
One-handed shot, hook shot, two-handed shot, jump shot, lay-up, tip-in, free-throw, and dunk.
- Name at least three types of passes.
Two-handed chest pass, two-handed overhead pass, one-handed overhead pass, one-handed underhand pass and bounce pass.
- Name two defense techniques.
Two defense techniques include the zone and the player-to-player defense.
- What is the difference between a fast-break and a slow-break offensive style?
A fast-break offense includes quick passes from the rebounder to the guards who typically run from defensive positions to offensive positions as soon as their opponents shoot the ball. A slow-break offense gives the offense time to set up and run their planned plays.

Physical Education 5 Answers

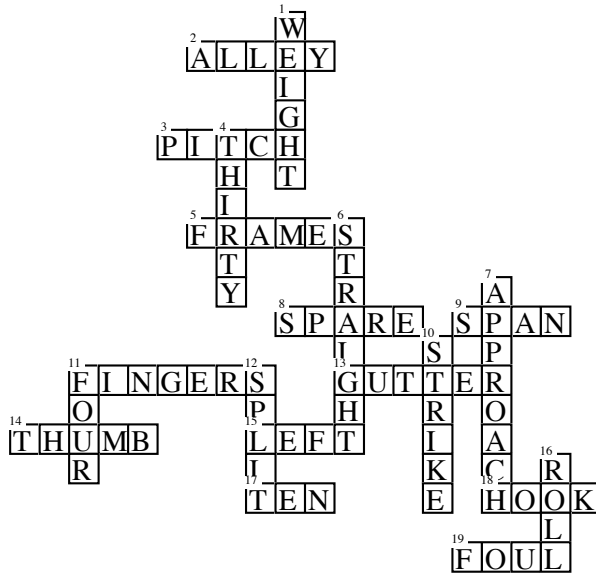

E H H R H H A S O E E R U **W E I G H T** H T O L T P O H F
 I L O L T R R **S P A R E** O T F S R N N U I **F R K S L A R**
 T O I L M P L O T U F U F A F T G R F R O A R **P H E O I**
 F O O H **G U T T E R S** T K N E I M O H G R P T **A L T E O**
 Y U H R P A T A P N **P H E P F S S** **P I T C H E R M H T F**
L T O R F O U R R A T R F I L R A P P R O A C H E R F
S E U N T U T T R M N L S R Y N P T I L L R E M I L S I
G S F R H E E F U R T O P R L G N I T H I R T Y A T G S
 F L R **T T T P L L I A R S P L T L S F O U L F A L S S E**
 U E E L N P F T **R R E E U S S P R F G P N T A L N C P L**
 L L T G S T L I **O B T T Y S T H A P I L I B H E P E G I**
 T G T H T **A E I L S T R I K E R E L H E T L H P A E Y C**
 A I P R O W **L T L G A H T U A G A G S H F I N G E R S H**
 O L E S I F L **L O S L O N P S T U I R T T L T U B E E R**
 H H U T A T I P **E P P L A F L U A O G T A N T L T P H A**
 E T T N W G N I S **Y H L U E U I Y P O H S T T H U A C T**
 T R P S T T N A G P E P **I P F H P E O N T L S O U O M K**
 O S L H I S R **T E N L I W T R F E S O H A A K E S M H C**
 L A L F F R T O T U E F T T H L N N T O F U L R N L **B T**
 O T G I H T U S E T U H H Y T S T H T **H O O K O F I N F**

1. What are the physical benefits of bowling?
Bowling provides moderate exercise benefits - muscles are stretched in the arms, legs and back.
2. What basic equipment is needed for bowling?
A bowling ball and bowling shoes are the essential pieces of equipment needed to bowl.
3. What factors are important in selecting a bowling ball?
Weight, span and pitch must be considered in selecting a bowling ball.
4. Describe the stages in a four-step delivery.
Bend forward, move the right foot forward, hold the ball forward and to the right, swing arm back and fully release.
5. What is meant by “follow-through” in bowling?
When the ball is released, the thumb comes out first, followed by the other fingers. The arm is in a forward position and rising.
6. What are the four basic shots in bowling?
Straight ball, hook ball, curve ball, backup ball.
7. What is a split ball?
A split ball occurs when the headpin is down and the remaining pins have another pin down immediately ahead of or between them.
8. What constitutes a foul in bowling?
A foul occurs when a player’s foot goes beyond the foul line.
9. How many times does each player get to bowl in a typical game?
Usually, a player will bowl twenty times during the game. This number can be more or less depending on the number of strikes and spares achieved.
10. How many frames are there per game? How many possible points can a bowler make? What would be a good score in bowling for a beginning bowler?
There are ten frames for each game. A perfect score would be 300 points. A score of 120 would be good for a beginning bowler.

Physical Education 6 Answers



1. What are the physical benefits of playing soccer?
The player's arms, legs, heart and lungs all get a good workout during the average soccer game.
2. True or False: Soccer players are allowed to touch and carry the ball in the hands.
False. The arms and hands are not used in soccer.
3. How long is the average soccer game?
A soccer game is usually two 45 minute periods long.
4. Describe an overhead kick in soccer.
This is a kick to send the ball in the opposite direction from the one in which the player is facing.
5. What does it mean for a player to "trap" the ball?
Trapping the ball means that a player attempts to control a ball by stopping it or changing its direction.
6. When should the technique of "heading" be used?
Hitting the ball with the flat part of the forehead is called heading. It is used when the ball is too high to reach with any other part of the body.
7. What actions in a soccer game might result in a foul being called?
Fouls are given for such actions as kicking an opponent, striking or pushing an opponent and touching the ball with the hands or the arms.
8. Describe the makeup of a typical soccer team.
A soccer team is composed of eleven persons including one goalkeeper, two backs, three midfielders, three strikers and two wingers.
9. Which soccer players on a team are usually considered to be the best all-around players?
The strikers are considered to be the best all-around players.
10. How do you make a goal in soccer?
A goal is made by kicking or heading the ball into the goal net.

Physical Education 7 Answers

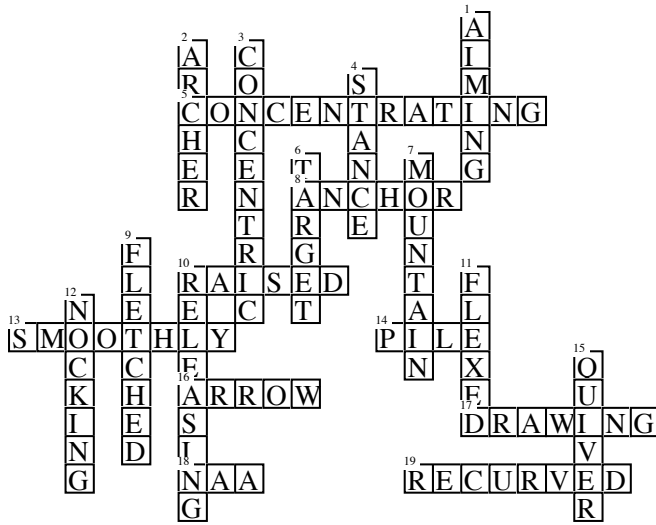

N O C K I N G G E Q C G R R R G **T A R G E T** L G D G D
 I O C O **C O N C E N T R I C** N U C X E I T O T E E A T
 N G A S **F L E T C H E D** E N N **P I L E** L R F I O R D T
A I M I N G T E A U I O E A I A R I W R U G T T A E A
 T S A D I T O **C W O P E H A R T** **R E C U R V E D** G I A
 I W R R R N X I **O V V N O N T E M N W H C G M G S O C**
 R O O A H R H R E **N I C E E A G A A T N R U O R R E A**
 A E A E N O N A F R **C N I C I P R T N N T A** **S A N A D**
 F I M N H N I A A I E **E D O T A R R O W** N A **T V O E R**
 S D E D I P W D R I D **F N O U A G S R O R A** **A C L O G**
N M O U N T A I N E I **L E T N I R G** T H E E **N R N T D**
N D O E A C R R O T E **E F E R I V C E R P** **S C C O N R**
A N N E L R A C E C S **X N D E A L E H S H M E R A N A**
A E I D I X S D I A E N D E C L N T N R E E O M F A I W
R E L E A S I N G N N D A C R S W **I L N R O** H A A E **I**
 O C R T K E C G I **C R R N W E A R R N H W T** T X E R **N**
 T A R C W C A C N **H A N R R O L R A T G R** **H C C L E G**
 A A U S H S D R N **O C U R D C K I A D R A** **L A A C I M**
 T S H A H P M C T **R A E O A A I N U G E R** **Y O N C R U**
 C R I E N U E G **R A I S E D** V E D E A C P P E N A L G

- What are the physical benefits to be derived from archery?
Archery improves finger dexterity and develops arm strength.
- What are some of the factors an archer must consider in his or her choice of a bow?
It is always best to buy a bow that is light enough for the person using it. The length of the bow must be appropriate also.
- What is the “draw weight” of a bow?
Draw weight refers to the amount of weight in pounds one would have to attach to a bowstring to bend an immobilized bow a certain amount.
- What basic pieces of equipment are needed to get started in archery?
One needs a stringed bow, arrows and a quiver. Some archers may also want to use an arm guard.
- Describe the ten steps in shooting a bow and arrow.
Proper stance, correct bow arm and grip, nocking, drawing, anchoring, relaxing, aiming, concentrating, releasing and follow-through.
- True or False: A good archer keeps his or her body and arm tense and rigid at all times. Explain.
False. Muscles should not be too tense or the draw will be executed improperly.
- What do beginning archers need to do before they begin to practice archery?
They need to select the right equipment and they also need to learn the right shooting technique before practicing the sport.
- Should you ever shoot an arrow straight up into the air? Explain.
No. Arrows shot straight up can come straight down. This is dangerous.
- Why is concentration so important in archery?
The ability to concentrate in archery often makes the difference between excellent and average performance.
- What does “follow-through” mean in archery and why is it important?
“Follow-through” means to hold your stance for a few seconds after releasing the arrow.

Physical Education 8 Answers

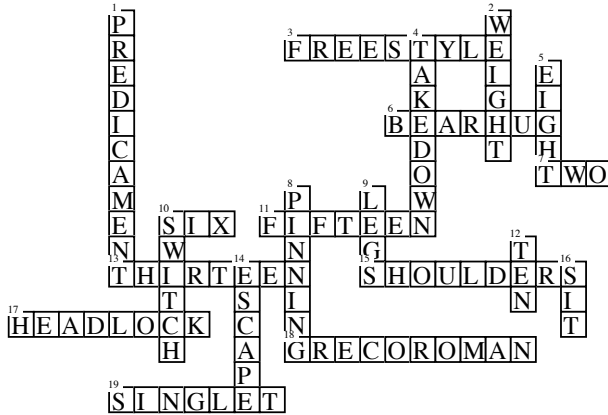

1. What physical benefits can be gained from wrestling?
Almost every muscle in the body is used in wrestling. Wrestling training produces strength, speed and endurance.
2. What are the two most popular styles of wrestling practiced in the United States?
The two most popular styles of wrestling in the US are Greco-Roman style and freestyle.
3. How long is an Olympic wrestling match? a high school match? a college match?
At the Olympic level, a match is made up of three three minute periods.
A HS match is made up of three two minute periods. A college match is made up of one two minute period followed by two three minute periods.
4. How are wrestlers grouped?
Typically, wrestlers are grouped by weight.
5. What is a “takedown” in wrestling?
A takedown is when one wrestler gains control over another wrestler by bringing him or her down.
6. Name three different ways to win a match.
Three ways to win a match are by a pin, a technical fall/15 point lead, or by winning the most points at the end of the match.
7. What is a “predicament?”
A predicament is a two-point move that occurs when one wrestler controls the other.
8. What is a “reversal?”
If a wrestler frees himself or herself from the opponent’s control and then gains control of the opponent, a reversal has taken place.
9. Why are psychological factors so important in wrestling?
All other things being equal, a wrestler has a better chance of success if he or she has a strong will to win.
10. What two types of takedowns rely especially on strength?
Two takedowns that relay on strength are the bearhug and the headlock.

Physical Education 9 Answers

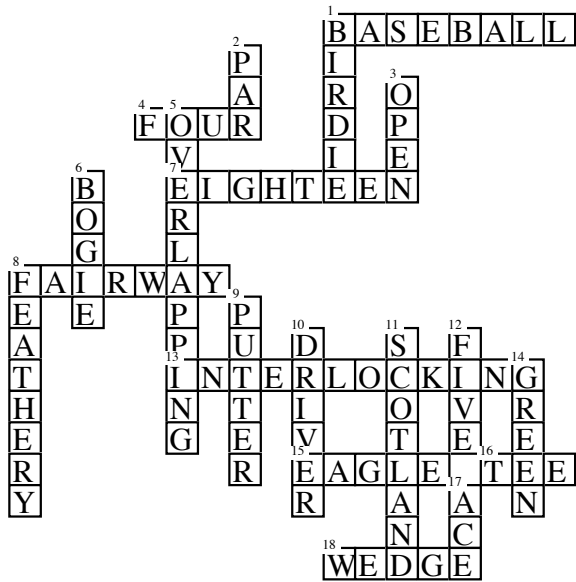

I O B O G I E I I P Y H E B N G N E A P D E G I T A
 S C O T L A N D I V U E F E G E A S I B B I B G V O
 F B L R E O E F N T E T A E E T D K E G E A N E O W
 I V A N U N E V T U E F T E G I O P A R E W B G N E
 V F A E A D A N E F N E G E N N G E E W N N A A P O
 E E P C D D A E R A E W T W R A H H E E E E E S T V
 E R C B S E E E L B N A E E R E G D T L E D N E V E
 R B D I N I I I O R B E T E A R I A I E E T G T D R
 R I E E T P I P C A U A O H I I G P A N E T E E G L
 E P I E B C E E K G R I S N E F O U R H R N D N I A
 E Y R F B F D T I D C V O E N R Y E P E A G T W T P
 U O T T I E E E N T B B G T B I Y R R G E R V D I P
 D P E O R D I T G E E L E W O A N G E O D P B E K I
 E E S E D E W G E L R C U W L S L E L E E D R E L N
 E N E H I L D R A R E E R B R A D L A C E T A P I G
 E W D O E B C E G U S I E A G L E N R R R E R C A T P
 E E T T H Y R E F A I R W A Y A A A E R O I T E E R
 R U E P P P I N E R A F D L F I R E D R I V E R P A
 E E Y R E W R O T E E N R O E O N E A G N P O I F E

1. What physical benefits can be derived from playing golf?
 Golfers who walk the course get some cardiovascular benefit from this light form of exercising. Golf helps keep one's body limber and toned.
2. Is golf really just "a rich person's game?" Explain your answer.
 There are inexpensive golf clubs that can be purchased and many public courses can be played for a reasonable fee. Of course, Country Club golf can be very expensive.
3. What is a birdie? a bogie? an eagle?
 Hitting the ball into the hole one stroke under par is a birdie. A bogie is when a player hits the ball into the hole in one stroke over par. When a player hits the ball into the hole with two strokes under par it is called an eagle.
4. What does it mean to say that a ball ends up "in the rough?"
 The rough is an area off the fairway where there may be tall grass, trees, or shrubs.
5. Why does a professional golfer usually own many types of clubs?
 Professional golfers want their shots to be very precise. Each club has a different angle and therefore, does a different job if hit properly.
6. Name three types of grips in golf.
 The three grips are: interlocking, overlapping and the baseball.
7. Name six steps in making a smooth swing.
 The six steps include: addressing the ball, full backswing, keep your eye on the ball, rotate hips on downward swing, follow-through after hitting the ball, and make every swing a full swing.
8. Name two things that are fundamental to good putting?
 The answer should include two of these three: keep your eye on the ball, keep your head still, and follow through.
9. How should you warn other players of an approaching ball?
 If your ball heads toward another player you should yell "fore!" to warn him or her.
10. What should you do after you step out of a sand trap?
 You should rake a sand trap smooth after stepping out of it.

Physical Education 10 Answers

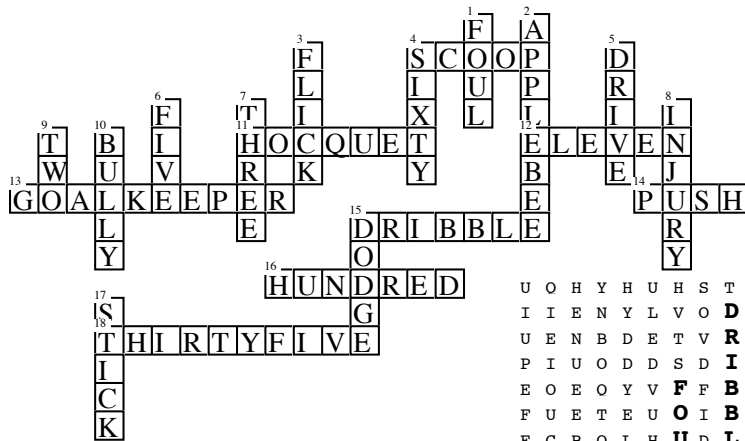

U O H Y H U H S T D V R K E D U A D E P T P V F E B E O D
 I I E N Y L V O D O E E R C V F O R A S W D O X S F Y S E
 U E N B D E T V R D X P L O G B I R U I O U H E I U O O P
 P I U O D D S D I G E P B E C O P V L E N J I R E L P B B
 E O E O Y V F F B E C T I E F O A U E E T X E S D S L Y L
 F U E T E U O I B R K E L E V E N L S D H D O E Y B H O W
 E C B O L H U D L L C O G E E S T K H R O L I R T U L T
 O R B I H L L T E F K I S L E F E F A E E G H B F N N R S
 I H J U P P E R E O L O O R B H K L P J E Y H R E C D T T
 D L U P L U D T U L U G V T B Q L I T D C P X O W U R P I
 I H V P P L B T K A D N N O L V I C L F A D E O L D E F C
 V P S I T U Y I X Y P E H B P I F K D E P E I R S R D H K
 V O U O O R Y T Y R U P P S O C N P N S Y U S T I I S O K
 F R O L I D H K E R S W L P K U I J E B V N I P X V T D U
 I U G E N F B E T E R L D E H O C Q U E T S L H T E D D I
 I D S D N U E E D F P H S I B K L A E R E G T T Y O P L O
T H I R T Y F I V E E E T F W D E O V C D Y G S O C P U R C
 T S T S C L D I Y S I E H V A E E F D I U S C O O P E W L
 T L O E V U S T C T C I D O C L B N E C A P I G V E D E I

- What are the physical benefits to be gained from playing field hockey?
 Field hockey is a physically demanding sport. Vigorous play can have a positive effect on one's cardiovascular system.
- How many persons comprise a hockey team? What positions do they play?
 A hockey team has eleven players. Five forwards, three halfbacks, two fullbacks, and a goalkeeper make up the team.
- What does the term "bully" mean?
 The term "bully" in hockey describes a method used by two opposing players to restart play.
- True or False: All the players on a hockey team can use their feet or bodies or the stick to stop a ball.
 False. Only the goalkeeper can use his or her feet or body or stick to stop a ball.
- Name five common reasons for a foul in hockey.
 Five fouls are: raising the stick above the shoulder, advancing the ball with the hand, hooking or grabbing an opponent's stick with another stick, undercutting or causing the ball to rise too high in the air, and obstructing by putting a stick or body part between the opponent and the ball.
- Why has hockey been somewhat slow to catch on at the high school level?
 One reason for the slowness is the expense of purchasing the required equipment.
- Name at least three attacking skills that a hockey player should know.
 Any three of the following: the drive, the dribble, the scoop, the flick, the push, the dodge.
- What is "a scoop?" and what is a "dodge?"
 The scoop allows the player to scoop the ball far enough off the ground to clear the opponent's stick.
 A dodge is a maneuver to avoid the opponent while keeping possession of the ball.
- What should a player do when it is impossible for him or her to attempt a goal.
 If it is not possible to attempt a goal, the ball should be passed to a teammate.
- Where should a player's attempt at a goal cage be aimed?
 A player should aim at a specific spot in the goal cage - preferably an area left unguarded.

Physical Education 11 Answers

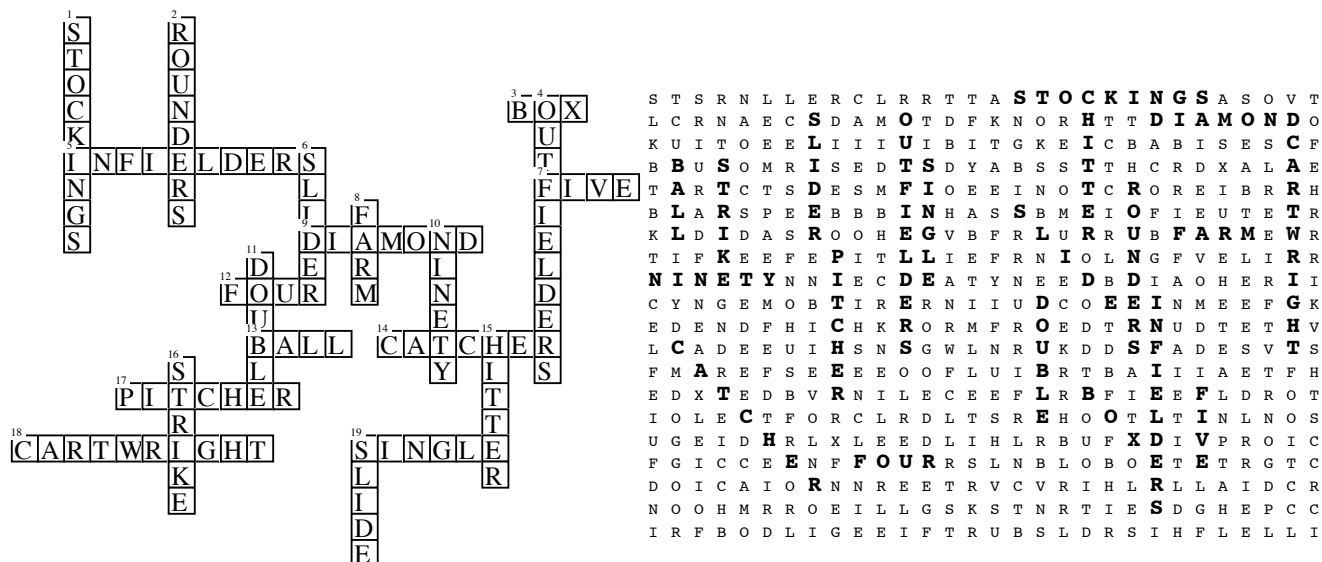

- Baseball is often identified as the great American sport, yet it didn't begin in America. How and where did this game originate?
It probably began in England around 1744.
- What are some of the physical benefits to be derived from playing baseball?
The physical benefits include exercise of the upper body - throwing and hitting, of the lower body - running, and development of hand-eye coordination.
- What are "farm teams" and how are they used?
Farm teams are run by major league teams to help train players for the big leagues.
- How many people make up a typical baseball team and what positions do they play?
9 or 10. Pitcher, catcher, first baseman, second baseman, short stop, third baseman, left fielder, right fielder, center fielder, and, in some leagues, designated hitter.
- What is a "single?" "a double?"
A single is a hit where the batter makes it to first base and no further. A double is a hit where the batter makes it to second base and no further.
- When does "a ball" occur?
When a thrown ball is out of the strike zone and the batter does not swing it is called a ball.
- How is a good slide into a base executed?
The body falls to the ground in a controlled manner by a fall backward on the outer surface of the knee and lower leg.
- Why is the pitcher considered the most important defensive player on a team?
The pitcher is the one who will either strike the batter out or permit the batter to get a hit. By preventing hits, a pitcher can dominate the game.
- Name at least four factors involved in executing a good throw:
First you need a good grip, second you need to use the proper stance, third the player's entire body must be used in the throw, and fourth, the arm must follow through once the ball is thrown.
- What are some of the effects of the baseball strike in 1994? In your opinion, will baseball ever return to its pre-1994 status as the most popular spectator sport in North America?
Some of the effects include decreased fan attendance at games and a loss of interest by many. Answers will vary.